

Lastolite™

By **Manfrotto**



Backgrounds and Lighting Control Systems

YouTube

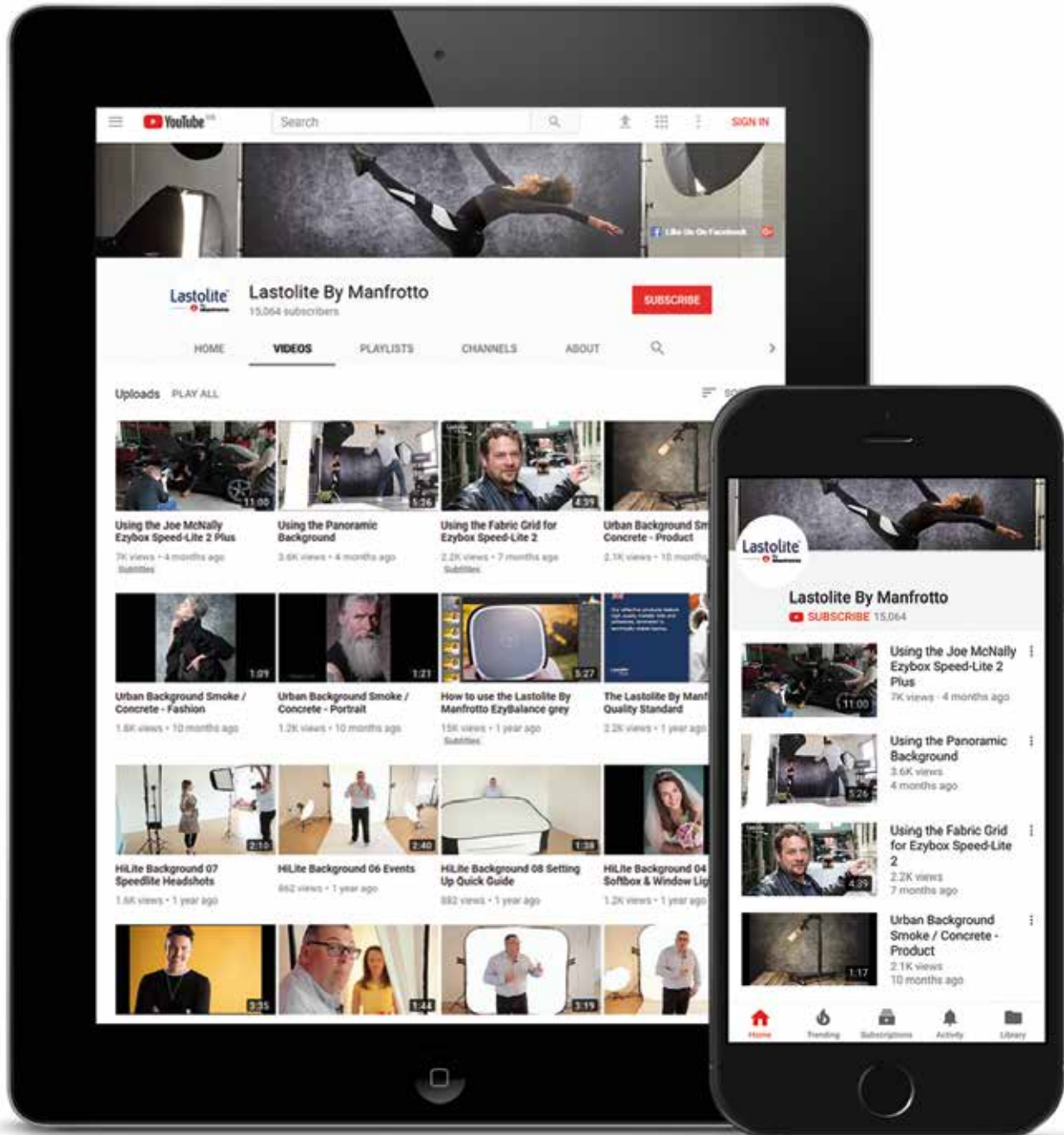

Visit www.youtube.com/lastolite

To view our videos showing how professional photographers use our products.
Over 85 videos offering in excess of 18 hours of free, comprehensive tutorials.



Like us on Facebook
[@lastolitebymanfrotto](https://www.facebook.com/lastolitebymanfrotto)



Follow us on Instagram
[@lastolitebymanfrotto](https://www.instagram.com/lastolitebymanfrotto)



Follow us on Twitter
[@lastolite](https://www.twitter.com/lastolite)



Index

The History	2
The Quality	4
Reflectors & Diffusers	
Trigrip	7
Circular	11
Panelite	11
Triflector MkII	13
Skylite Rapid	14
Colour & Exposure Controls	
EzyBalance	16
XpoBalance	16
Continuous Lighting	
RayD8	17
Flashgun Modifiers	
EzyBounce	18
Introducing Strobo	30
Strobo Direct to Bracket	32
Strobo Direct to Flash	32
Strobo Accessories	33
Flashgun Softboxes	
Ezybox Micro	20
Ezybox Speed-Lite 2	21
Ezybox Hotshoe	22
Multi-fit Softboxes	
Ezybox Pro	24
Megalite	46

Flashgun Brackets & Accessories	
TriFlash Shoe Lock	35
Quad Bracket	35
Off Camera Cords	41
Brolly Grip	41
Joe McNally Signature Range	
Introducing Joe McNally	36
Joe McNally Ezybox Speed-Lite 2 Plus	37
Joe McNally Ezybox	38
Joe McNally 4 in 1 Umbrella	38
Joe McNally TriFlash	39
Joe McNally Skylite Rapid with Masks	39
Joe McNally UpLite	40
Joe McNally Ironworks Background	40
Umbrellas	
8:1 Umbrella	42
Umbrellas - Dual	43
Umbrellas - All in One	43
Umbrellas - Essentials	44
Mega Umbrella	44
Trifold Umbrella	45
Umbrella Kits	45
Portable Backgrounds	
Plain colours	47
Urban Backgrounds	48
Perspective Backgrounds	50
Out of Focus Backgrounds	51
Dyed colours	52
Dyed Knitted Ezycare	53
Panoramic Backgrounds	54
HiLite Backgrounds	57

ChromaKey Backgrounds	
Collapsibles	60
Curtain	61
Seamless Backgrounds	
Paper Roll Backgrounds	62
Vinyl Roll Backgrounds	63
Background Supports	
Magnetic	64
Solo	65
Traditional	66
Product Photography	
Cubelite	67
Studio Cubelite	69
LiteTable	70
ePhotomaker	70
Brackets & Handles	
Camera Bracket	71
Tiltheads	71
Handles	71
Lighting Stands	
Stands	72
Lighting Stands Accessories	72
Posing	
Posing Tubs	73
Baby Posing	73
Full Product Index	74



Some of the products featured in this brochure may not be available in your country. Product codes may also differ. Please check availability and product codes with your local distributor.

The specifications shown in this catalogue are based upon the latest information at the time of printing. In line with our policy of continual product development Manfrotto LTD. reserve the right to make changes at any time, without notice, to specifications and models and to discontinue items.

The History

A simple idea of creating a portable, pop-up photographic reflector sparked not only a revolution in imaging but put the wheels in motion for Lastolite to grow from a tiny, family-run company to an internationally-renown industry leader that thrives on innovation.

Right from its humble start, Lastolite has designed innovative and keenly-priced products to help keen photographers and professionals take even better shots. With an ever-growing portfolio of products, In 2011, Lastolite became part of the Vitec Group - a multinational holding company specialized in supporting professional photographers, broadcasters and filmmakers.



That's a huge achievement in a relatively small time, as the original Lastolite company was established in 1978 and owned by Coats Viyella - a global leader in textiles.

Six years later, former Coats Viyella employee Martin Henry purchased the company which still had only one product, the now famous circular collapsible reflector. It was the product that made reflectors truly portable, taking them out of the studio and onto location everywhere.

Martin immediately moved the business to the small village of Congerstone in Leicestershire, England. He began manufacturing from the family home, utilising the garage, kitchen and dining room. Martin's wife Margaret and their son Sean joined the team.

Martin saw great potential to expand the business beyond the UK so the family took a driving holiday through Europe, appointing five international distributors along the way.

The business soon outgrew the family home so Lastolite moved to their first industrial premises, a small 500 sq ft building in a nearby town called Coalville.

As the reflectors gained global acceptance, Martin used the same technology to launch the world's first collapsible photographic background at the 1988 Photokina trade show - the first time Lastolite had exhibited there. The new products triggered another period of significant growth and later that same year the business had to move again, this time to a new 4000 sq ft facility.



Left: The first building rented by Lastolite when production moved out of the Henry's home.
Right: Martin and Margaret Henry.

Over the next 15 years, Lastolite flourished, with a range of more than 30 products sold in more than 60 countries worldwide. Again the business moved to a larger 12,000 sq ft factory.

In 2004 Martin Henry decided to take a step back from the day-to-day business allowing his son Sean to take control. With a strong global distribution network, Sean turned his attention to what Lastolite became famous for, innovation.



Lastolite machinist from 1988

Over the next few years Lastolite tapped into huge changes in the photography market as digital technology and off-camera flash took hold. It was in this period that Lastolite launched some of its most successful products including the TriGrip, Hilite, Cubelite and Ezybox Hotshoe. By the end of 2006 Lastolite had firmly established itself as the world's leading manufacturer of backgrounds and light control systems.



A year later Lastolite acquired Colorama Photodisplay, the world's largest manufacturer of seamless background papers. The business was again re-located to Coalville to a new 22,000 sq ft facility.

As business continued to grow, Lastolite was awarded the 2011 Queens award for Enterprise in recognition of the company's international trade achievements. Then in 2012 Lastolite and the Manfrotto UK distribution company both relocated to a state-of-the-art 44,000 sq ft facility in Ashby-de-la-Zouch. The success story continues.



Lady Gretton, Lord-Lieutenant of Leicestershire presenting Sean Henry with The Queen's Award for Enterprise: International Trade

The Quality



At Lastolite By Manfrotto we not only make a range of innovative accessories to help photographers and film-makers take great shots, but we also take pride in offering world-class products manufactured to the highest quality, ensuring they can withstand the repeated daily use of the most demanding image-maker.

To keep our leading edge, we make significant investments into research and development to ensure that we can continue to launch new and innovative products to meet the needs of the ever-changing photo

and video markets. Allied to our strict quality standards and attention to detail, we are always looking at ways to improve the way our products are manufactured, too. We are consistently developing new ideas and technology which leads to investment in bespoke tooling and mouldings. With the vast majority of our fabric-based products made in our huge Leicestershire factory, we retain close control over quality.



High quality sprung steel is used inside all of our collapsible products. The steel is 'dressed' to ensure all the sharp edges and dirt are removed to ensure no damage is incurred during use and provide maximum longevity. To join the ends of the steel together we use a range of specially designed, heat treated clips that guarantee a permanently strong fix for the lifetime of the product. For added peace of mind we offer a lifetime warranty on the steel rim in all of our products.



The steel rim is incorporated into our products by inserting it into our specially designed rim tape. The rim tape is made from a hard wearing, woven elasticated construction designed to withstand the typical knocks and scrapes from daily use by a busy photographer. The thick woven construction prevents the steel from wearing through and potentially weakening the structure of the product.



We apply the same level of detail and quality to all of our textiles as well. Each fabric is manufactured to meet the needs of the product, specifying the construction of the weave and the type of raw materials used. Each fabric is then coated or processed depending on the technical performance required. The textiles are also tested to make sure they meet the correct performance levels over repeated use and in adverse conditions. We have developed a range of over 10 different technical fabrics used to manufacture our products, including our patent protected innovative TriGrip Difflector fabric.



Our diffuser fabrics are manufactured using only the finest whiteners to reduce any chance of unwanted colourcast. The fabric is also specially coated to ensure colour balance and a uniform spread of light as it is passed through the material, avoiding typical issues such as irregular distribution and hot spots.

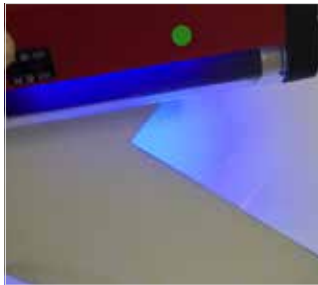

Our reflective surfaces are also specifically designed for our products and not general purpose textiles. We incorporate the correct level of stretch into the weave of all our fabrics to ensure the foil surface remains intact and does not crack under tension and lead to delamination. We also use the highest quality adhesive and lamination processes to ensure the foil remains bonded to the textile throughout the products lifetime and provides a uniform opaque surface to bounce the light.



And finally to hold our products together we use a triple thread, twin needle, loop stitch which provides maximum strength and durability.



“ I love using the Lastolite TriGrip reflectors - I can take photos whilst simultaneously holding the reflector. The grip allows me to comfortably and securely hold the reflector so I can accurately bounce light onto my model with one hand. Perfect if you are working without an assistant or if you're on the move. They fold up nice and small like your standard circular reflector and never lose shape. An incredibly useful light shaping tool for every photographer. ”

Nicole Gomes, Nicole Gomes Photography.



The triangular structure of the TriGrip makes it easy to hold in one hand with the camera in the other or for an assistant to hold one in each hand.



The securing strap allows the user to support the reflector without actually gripping the handle, reducing pressure on the wrist and fingers when held for prolonged periods.



The TriFlip covers make the TriGrip even more versatile. Simply slide the TriGrip into the cover to change the surface.

Reflectors & Diffusers

TriGrip

The TriGrip reflectors utilise a triangular design which provides a much stronger and stable structure. They also feature a moulded handle with a securing strap, allowing even more accurate positioning of the reflector with just one hand, which means that light can be directed to all those awkward spots e.g. under the chin and eyes without the need for stands or supports. The securing straps also allow you to support the reflector without actually gripping the handle, reducing the pressure on your wrist and fingers when held for prolonged periods.

TriGrip designed by Gary Astill. A registered design.

Features and Benefits

- ▶ Hold the reflector with just one hand
- ▶ Hold 2 reflectors, one in each hand
- ▶ New moulded handle with strap
- ▶ Double sided
- ▶ Collapses to a third of its original size

Silver / White

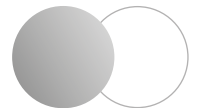

Gold / White

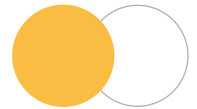

Sunfire / Silver

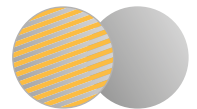

Sunlite / Soft Silver

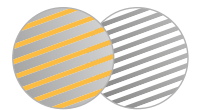

Diffuser 1 Stop

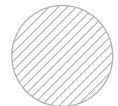

Diffuser 2 Stops

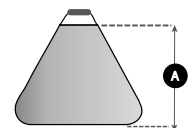
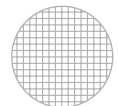

Without TriGrip



Without TriGrip



With TriGrip



With TriGrip

Specifications

TriGrip Mini	A	Code	TriGrip	A	Code	TriGrip Large	A	Code
Silver / White	45cm (18")	LL LR3531	Silver / White	75cm (30")	LL LR3631	Silver / White	1.2m (48")	LL LR3731
Gold / White	45cm (18")	LL LR3541	Gold / White	75cm (30")	LL LR3641	Gold / White	1.2m (48")	LL LR3741
Sunfire / Silver	45cm (18")	LL LR3536	Sunfire / Silver	75cm (30")	LL LR3636	Sunfire / Silver	1.2m (48")	LL LR3736
Sunlite / Soft Silver	45cm (18")	LL LR3528	Sunlite / Soft Silver	75cm (30")	LL LR3628	Sunlite / Soft Silver	1.2m (48")	LL LR3728
Diffuser, 1 Stop	45cm (18")	LL LR3551	Diffuser, 1 Stop	75cm (30")	LL LR3651	Diffuser, 1 Stop	1.2m (48")	LL LR3751
Diffuser, 2 Stops	45cm (18")	LL LR3507	Diffuser, 2 Stops	75cm (30")	LL LR3607	Diffuser, 2 Stops	1.2m (48")	LL LR3707
Collapses to 20cm (8")			Collapses to 30cm (12")			Collapses to 51cm (20")		

TriFlip 8:1

Never get caught out again, up to 8 surfaces in the same bag. The TriFlip are designed to increase the versatility of the TriGrip reflector. Simply insert the TriGrip into the TriFlip sleeve for instant access. TriFlip surfaces: Silver, White, Soft Silver, Gold, Sunfire, Sunlite and Black.



Features and Benefits	
▶	Sleeves are double sided and reversible
▶	Eight different surfaces
▶	Set up in seconds
▶	Taut professional finish

Specifications		
TriFlip 8:1	A	Code
TriFlip 8:1 Kit	75cm (30")	LL LR3696
TriFlip 8:1 Mini Kit	45cm (18")	LL LR3596

- Kits contain:
- 1x TriGrip 2 Stop diffuser
 - 2x Double sided, reversible TriFlip covers:
 - Silver / Soft Silver, Sunlite / Sunfire
 - Gold / Black, White / Black

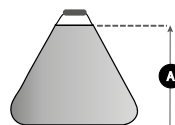

TriFlip 8:1 Deluxe Kit

The TriFlip 8:1 Deluxe Kit provides a complete all in one solution for the busy photographer. The kit comprises: 1 x 75cm (30") TriGrip 2 stop diffuser, 1 x set of 75cm (30") TriFlip covers containing White, Silver, Soft Silver, Gold, Sunlite and Sunfire reflective surfaces as well as a Black surface, 1 x air cushioned lighting stand 99cm - 298cm (39" - 117"), 1 x TriGrip Bracket and 1 x carry case with shoulder strap.



Specifications

TriFlip 8:1 Deluxe Kit	A	Code
TriFlip 8:1 Deluxe Kit	75cm (30")	LL LR3699

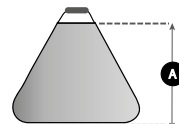

TriGrip Bracket

The TriGrip bracket is ideal for photographers who work alone and want to support the TriGrip reflector on one of our extending handles, a lighting stand, tripod or any other type of fixing bracket (a spigot connector may be required). Simply place the moulded TriGrip handle into the bracket and secure it in place with the strap. The ball joint connector enables you to then position the TriGrip exactly where you want leaving your hands free to operate the camera.

The bracket can be used to support the TriGrip when working with ambient light or in conjunction with battery operated flash using the flash gun attachment arm to bounce light off the reflectors surface or shoot through a diffusing panel.



Features and Benefits

- ▶ Ideal for photographers who work alone
- ▶ Compact foldaway design
- ▶ Compatible with battery operated flash guns
- ▶ Multi position ball joint connector

Specifications

TriGrip Bracket	Code
TriGrip Bracket*	LL LA2430

* Not recommended for use with the large TriGrip.



Reflectors & Diffusers

TriGrip Difflector PATENTED

The TriGrip Difflector is the world's first dual purpose reflector panel which can be used as a diffuser (2.3 stops) and a bounce reflector. The unique fabric developed for this product allows light to pass through one side and bounce off the other side, making it a truly versatile product whatever the lighting conditions. The difflector is available with a Soft Silver reflective surface.

The TriGrip Difflector also features the unique TriGrip moulded handle for accurate positioning of the reflector with just one hand.

Features and Benefits

- ▶ Hold the reflector with just one hand
- ▶ Hold two reflectors one in each hand
- ▶ Use as a diffuser or a bounce reflector
- ▶ Collapses to a third of its original size

Specifications

TriGrip Difflector	A	Code
TriGrip Difflector Mini Soft Silver	45cm (18")	LL LR3552
TriGrip Difflector Soft Silver	75cm (30")	LL LR3652
TriGrip Difflector Large Soft Silver	1.2m (48")	LL LR3752

Diffuser 2.3 Stop / Soft Silver

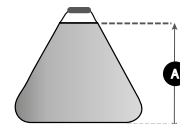
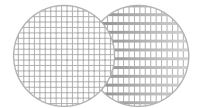

Without TriGrip Difflector



With Difflector diffuser only



With Difflector diffuser & Soft Silver reflector



Reflectors & Diffusers

Circular and Panelite Reflectors

The original and industry leading collapsible reflectors.

As well as the lifetime guarantee on reflector steel, we have also upgraded the rim tape on all reflectors to make them even more durable.



White



Soft Silver



Silver



Sunlite



Sunfire



Gold

Features and Benefits

- ▶ Collapsible / Reversible
- ▶ Lifetime rim guarantee
- ▶ Upgraded rim tape
- ▶ Six useful sizes and six essential colours
- ▶ Double-coated reflective surfaces
- ▶ Collapses to a third of its original size



Sunfire / White

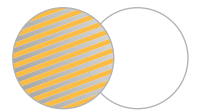

Silver / White

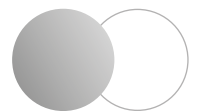

Silver / Gold



Sunfire / Silver

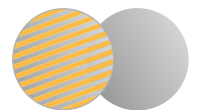

Gold / White

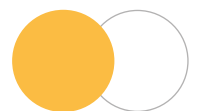

Sunlite / Soft Silver

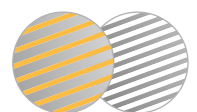

Diffuser, 2 Stops

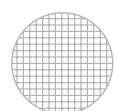

Specifications

Collapsible Reflectors						Panelite
Open Sizes	30cm (12")	50cm (20")	76cm (30")	95cm (38")	120cm (48")	1.8 x 1.2m (6' x 4')
Collapsed Sizes	14cm (5.5")	24cm (9")	30cm (12")	40cm (16")	48cm (19")	64cm (25")
Sunfire / White	LL LR1206	LL LR2006	LL LR3006	LL LR3806	LL LR4806	LL LR7206
Silver / White	LL LR1231	LL LR2031	LL LR3031	LL LR3831	LL LR4831	LL LR7231
Silver / Gold	LL LR1234	LL LR2034	LL LR3034	LL LR3834	LL LR4834	LL LR7234
Sunfire / Silver	LL LR1236	LL LR2036	LL LR3036	LL LR3836	LL LR4836	LL LR7236
Gold / White	LL LR1241	LL LR2041	LL LR3041	LL LR3841	LL LR4841	LL LR7241
Sunlite / Soft Silver	LL LR1228	LL LR2028	LL LR3028	LL LR3828	LL LR4828	LL LR7228
Diffuser, 2 Stops	-	LL LR2007	LL LR3007	LL LR3807	LL LR4807	LL LR7207

Reflectors & Diffusers

Bottletops 5:1

An innovation of the Lastolite By Manfrotto industry leading range of reflectors.

Simply slip the elasticated Gold / White or Sunfire / Silver cover over the reflector or diffuser to produce an instant change of colour.



Features and Benefits

- ▶ Sets up in seconds
- ▶ No extra weight
- ▶ Collapses to a third of its original size
- ▶ Five surfaces in one bag
- ▶ Taut professional finish

Diffuser Panel,
2 Stops

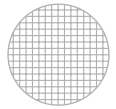

Gold / White
Cover

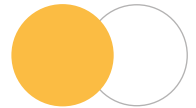

Sunfire / Silver
Cover

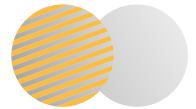

Specifications

Bottletop Accessories	Size	Code
Diffuser with Gold / White & Sunfire / Silver cover	50cm (20")	LL LR2096
Diffuser with Gold / White & Sunfire / Silver cover	75cm (30")	LL LR3096
Diffuser with Gold / White & Sunfire / Silver cover	95cm (38")	LL LR3896
Diffuser with Gold / White & Sunfire / Silver cover	120cm (48")	LL LR4896

Circular and Panelite Reflector Accessories

Suitable for all reflectors and bottletops, the following accessories allow for versatile positioning.



Universal Bracket LL LA1100



Panelite Bracket LL LA1107

Features and Benefits

- ▶ Wind resistant clips for outdoor use
- ▶ Adjustable in size

Specifications

Accessories	Size	Code
Universal Bracket	50cm - 120cm (20" - 48")	LL LA1100
Panelite Bracket	95cm - 180cm (38" - 72")	LL LA1107

Triflector MkII

The Triflector is widely used in makeovers and fashion shots because the subject is given the Triflector's distinctive 'catch lights' to the eyes. The hinge mechanisms make all three panels individually adjustable to get light exactly where you need it. The panels each fold like our collapsible reflecting panels; the frame folds away and they all fit into a portable bag. Triflector MkII weighs only 1.2kg (2.6lb).



Triflector in use for Portrait Photography



Without Triflector



With Triflector



Using with Beautydish



Features and Benefits

- ▶ Unique quality of light
- ▶ Weighs just over 1kg (2.2lb)
- ▶ Three reflective panels

Specifications

Triflector MkII	Code
Triflector Mk II - Sunfire / Silver*	LL LR2933
Triflector Mk II - Silver / White*	LL LR2933SW

* Includes adjustable framework and 3 x reflector panels

Triflector MkII Panels	Code
Set of three Gold / White reflector panels	LL LR2905
Set of three Silver / White reflector panels	LL LR2903

Triflector MkII Kit	Code
Triflector MkII with Sunfire / Silver panels & stand kit**	LL LR2933SP

** Includes adjustable framework, 3 x reflector panels and stand (LL LS1158 - see page 71)

Sunfire / Silver

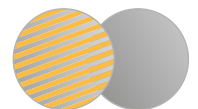

Silver / White

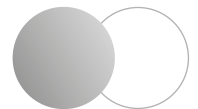

Gold / White

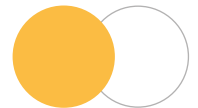

Translucent Fabric
reduces light by 1.2 stop

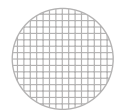

Reflectors & Diffusers

Skylite Rapid

For the location photographer who needs lighting control in the most demanding situations. The Skylite Rapid's collapsible but rigid aluminium frame delivers reliable performance even in windy conditions, while the Skylite Rapid covers simply clip in place to provide maximum versatility.

The Skylite Rapid frames, fabrics and accessories are all available separately, so you can mix and match as you choose.

For greater value choose our kit. The kit contains a Silver / White reflector, 1.25 stop diffuser, frame and rigid case.

Note: All Skylite frames are compatible with the original Skylite covers and Skylite Rapid covers.

Features and Benefits

- ▶ Aluminium frame
- ▶ Resistant to rust so ideal for outdoors
- ▶ There is an elastic cord running through the aluminium, so it's impossible to lose parts or leave anything behind
- ▶ Skylite Rapid covers clip easily into place for an impressively taut finish
- ▶ Kits include rigid case



Silver / White



Black / White

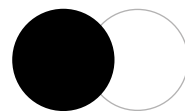

Sunfire / White

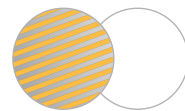

Diffuser 0.75 Stop

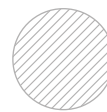

Diffuser 1.25 Stop

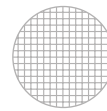

Black Velvet



Reflectors & Diffusers

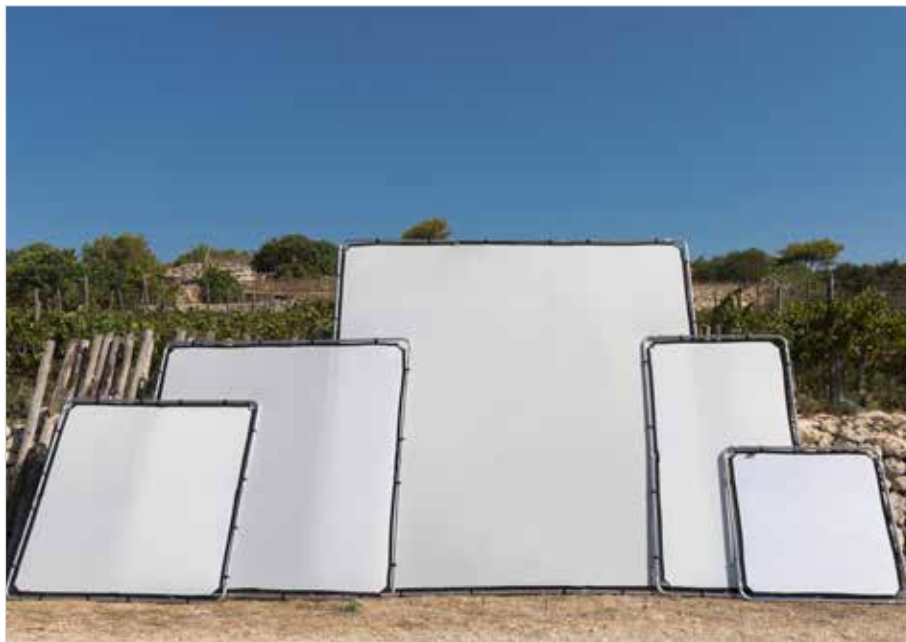

Skylite Rapid Accessories	Code
Skylite Rapid Griphead	LL LA8446
Skylite Rapid Crossbar Handle	LL LA8449
Rigid Case 78cm x 19cm x 14cm	LL LRCASE775
Rigid Case 103cm x 19cm x 14cm	LL LRCASE1025



Clip on covers for rapid assembly



Skylite Rapid Frame



Skylite Rapid Crossbar Handle LL LA8449



Skylite's special griphead allows it to be fixed to stands and tilted as required. LL LA8446



Skylite Rigid Cases

Specifications

Skylite Rapid Frames	Weight	Size	Code
Skylite Rapid Frame Small	1.1kg (2.4lb)	1.1m x 1.1m (3'6" x 3'6")	LL LR811
Skylite Rapid Frame Medium	1.6kg (3.5lb)	1.1m x 2m (3'6" x 6'6")	LL LR812
Skylite Rapid Frame Midi	1.5kg (3.3lb)	1.5m x 1.5m (5' x 5')	LL LR815
Skylite Rapid Frame Large	2.1kg (4.6lb)	2m x 2m (6'6" x 6'6")	LL LR822
Skylite Rapid Frame Extra Large	3kg (6.6lb)	3m x 3m (10' x 10')	LL LR833

** This table is not to size. Only to show you the columns and rows required

Skylite Rapid Covers	Small Covers 1.1m x 1.1m (3'6" x 3'6") Code	Medium Covers 1.1m x 2m (3'6" x 6'6") Code	Midi Covers 1.5m x 1.5m (5' x 5') Code	Large Covers 2m x 2m (6'6" x 6'6") Code	Extra Large Covers 3m x 3m (10' x 10') Code
Black / White	LL LR81121R	LL LR81221R	LL LR81521R	LL LR82221R	
Sunfire / White	LL LR81106R	LL LR81206R		LL LR82206R	
Silver / White	LL LR81131R	LL LR81231R	LL LR81531R	LL LR82231R	
1.25 Stop Diffuser	LL LR81107R	LL LR81207R	LL LR81507R	LL LR82207R	LL LR83307R
0.75 Stop Diffuser	LL LR81101R	LL LR81201R	LL LR81501R	LL LR82201R	LL LR83301R
Black Velvet	LL LR81102R	LL LR81202R		LL LR82202R	

Skylite Rapid Kits	Silver / White Reflector	1.25 Stop Diffuser	Frame	Rigid Case	Code
Skylite Rapid Small Kit	1	1	1	1	LL LR81143RC
Skylite Rapid Medium Kit	1	1	1	1	LL LR81243RC
Skylite Rapid Midi Kit	1	1	1	1	LL LR81544R
Skylite Rapid Large Kit	1	1	1	1	LL LR82243RC
Skylite Rapid Extra Large Kit		1	1	1	LL LR83344R

Colour and Exposure Control

White Balance and Exposure

Getting accurate colours and exposure is made easier with the Lastolite By Manfrotto range of EzyBalance and XpoBalance products. Simply take a test shot of your subject holding the product each time you shoot in a new lighting situation. You can then use a custom white balance on your camera to take a reading off the Balance card for perfect white balance and exposure.

Alternatively, you can use the eyedropper tool in one of the many post-processing applications to set your correct white balance, then copy and paste to the rest of your batch of images.

With different grey options plus black and white patches, the XpoBalance allows you to set even more colour tint options for a range of creative results.

EzyBalance **PATENTED**

The EzyBalance 18% is a handy double sided 'pop up' grey/white card which simplifies the complex technical issues surrounding exposure and colour correction when working in different lighting conditions.

A unique focusing target enables the camera to focus on the card and take the necessary readings. A waterproof version is also available for scuba divers.

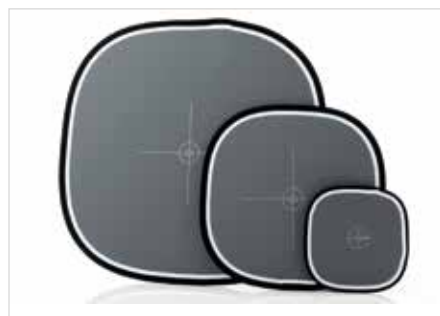

EzyBalance 18%



EzyBalance 18% (divers version) LL LR1252

Features and Benefits

- ▶ Colour correction, pre and post capture
- ▶ Exposure control, pre and post capture
- ▶ Accurate colour rendition
- ▶ Collapsible, durable and cleanable
- ▶ Double sided
- ▶ Unique focusing target
- ▶ For use with digital or film photography
- ▶ Collapses to a third of its original size

Specifications

EzyBalance	Code
30cm (12") 18%	LL LR1250
50cm (20") 18%	LL LR2050
75cm (30") 18%	LL LR3050
EzyBalance for Scuba Divers	
30cm (12") 18%	LL LR1252

XpoBalance **PATENTED**

The XpoBalance works in a similar way to the EzyBalance but has the added advantage of three different grey surfaces on one side and a black, white and 18% grey surface on the other side, collectively offering a range of white balance, exposure, colour correction and bracketing adjustment options.



XpoBalance LL LR1558



Specifications

XpoBalance	Code
38cm (15")	LL LR1558

Continuous Lighting

RayD8 c3200

The rayD8 c3200 is an entry level studio lighting head, ideal for product and portrait photography. Featuring a continuous tungsten light source (3200k), it provides a 'what you see is what you get' lighting effect for quick and easy set up.



Features and Benefits

- ▶ S type bayonet fitting
- ▶ Removable reflector
- ▶ Ideal for product photography

Specifications

RayD8 c3200 accessories	Code
1x light head, power cable and reflector* (Bulb not included)	LL LL3603
500w P 2/1 Tungsten bulb	LL LR3604



500w P2/1 Tungsten Bulb LL LR3604

RayD8 c5600

The RayD8 c5600 kit provides an entry-level studio lighting system for product and portrait photography. Featuring a high output compact fluorescent bulb (equivalent to 400w), this continuous light system offers colour corrected light at 5600k (daylight).

The bulbs are compact fluorescents and run at a low temperature, making them ideal for photographing food, people and other temperature sensitive subjects.



Features and Benefits

- ▶ Cool running, high output
- ▶ Colour balanced
- ▶ S type bayonet fitting
- ▶ Removable diffuser cover

Specifications

RayD8 c5600 accessories	Code
Colour corrected 85w fluorescent bulb	LL LR8036
Fluorescent Conversion Kit - Extension Tube & Fluorescent Bulb	LL LR8037

*Base head unit is interchangeable between the c3200 and c5600



Specifications

RayD8 c5600 kit	Light Head	Reflector 25cm (10")	Fluorescent Tube Extension	85w Bulb Fluorescent	Light Stand	Removable Diffuser	Code
RayD8 c5600 kit	2	2	2	2	2	2	LL LR8035

Flashgun Modifiers

EzyBounce

EzyBounce is a compact and foldable bounce card, the ideal accessory to help photographers achieve a softer lighting effect, eliminating the harsh shadows that may occur when using direct flash especially on-camera. Whether you're looking for a modifier to shape, diffuse or bounce light, EzyBounce is the solution.

EzyBounce mounts directly on the flash with a unique fixing silicon strap and it offers four different configurations for maximum flexibility. When not in use it can be folded to fit in a pocket or compartment of any camera case.

Features and Benefits

- ▶ Four different configurations
- ▶ Lightweight
- ▶ Secure and easy fixing silicon strap
- ▶ Carry case included

Specifications

EzyBounce	Code
EzyBounce Flashgun bounce card	LL LS2810





“ Lighting is the most important tool of the photographer, we spend our lives and career bending and shaping it to create our own individual signature. As we are judged on the quality of the work we create it is just as important to find the right tools that will help deliver consistent results and with style and class and ease.

Enter the Manfrotto Ezybox softbox range, a diverse and professional product that will deliver your light in a truly useable package. Easy and quick to assemble and sturdy enough to resist most of the elements that nature can throw at them, remembering that light can be both your friend and enemy – go embrace and tame it with the Ezybox softbox range and savour the results. Ezybox lights the way other softboxes will follow! ”

Eddie MacDonald, Eddie MacDonald Photography



A unique patented folding mechanism makes the Ezybox Speed-Lite 2 an ultra-portable, quick assembly softbox.



The Ezybox Hotshoe bracket securely supports the softbox while the flashgun simply slides into place and its position can be easily adjusted depending on its size.



The Ezybox Pro Softboxes assemble in a matter of minutes and the unique frame slots into the back of the box ready to attach the selected connector

Flashgun Softboxes

Ezybox Micro

A simple collapsible softbox which fits direct to your flashgun. The Ezybox Micro slides directly on to your gun and is secured in place thanks to an innovative internal frame structure and elasticated collar which requires no additional fixing mechanism to be permanently attached to your flash. Fits neatly in your camera bag - a great 'always with you' accessory.



Without Ezybox Micro



With Ezybox Micro



Without Ezybox Micro



With Ezybox Micro

Features and Benefits

- ▶ Simple slide on elasticated fitting
- ▶ No permanent fixing system attached to your flash gun
- ▶ Folds flat for easy storage
- ▶ 1-stop light loss

Specifications

Ezybox Micro	Size	Code
Ezybox Micro	W: 20cm x H: 14cm (8" X 5.5")	LL LS2211

* Not compatible with hammerhead style flashguns



Flashgun Softboxes

Ezybox Speed-Lite 2

**PATENT
PENDING**

The Ezybox Speed-Lite 2 is a 22cm x 22cm (8.5" x 8.5") mini softbox which attaches directly onto a flashgun whether it's on or off camera.

The softbox features a unique, design patented, folding mechanism with an innovative twist lock silicon strap for a quick and secure attachment to your flashgun, making it an ultra-portable, quick assembly softbox solution for today's busy photographers.

The Ezybox Speed-Lite 2 also features an inner and outer diffuser (both removable), which when used together, produces a 2 stop light loss, delivering an unrivalled softness of light. Incorporated within the internal folding mechanism are also two magnets which enable quick attachment of the Lastolite By Manfrotto Strobe honeycomb and gel holders for creative control of the light from the flashgun.

An optional diffused grid (45mm depth) is also available for greater control of the light.



Specifications

Ezybox Speed-Lite 2	A	B	C	D	E	Code
Ezybox Speed-Lite 2	23cm (9")	23cm (9")	22cm (8.5")	22cm (8.5")	22cm (8.5")	LL LS2430

Features and Benefits

- ▶ Assembled in seconds
- ▶ Removable inner and outer diffuser
- ▶ Folds flat for easy storage
- ▶ Optional grid available

Ezybox Speed-Lite 2 Accessories

Code
Fabric Grid for Ezybox Speed-Lite 2
LL LS2436



Compatible with Strobe honeycombs and gels



Optional Grid LL LS2436



Compatible with Strobe honeycombs and gels

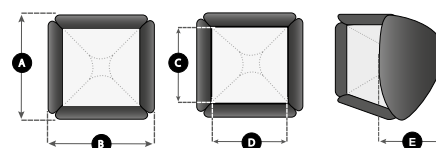

Flashgun Softboxes

Ezybox Hotshoe

The Ezybox Hotshoe converts your battery operated flash gun from a harsh directional light into a much softer diffused light and is available in three sizes - 38cm x 38cm (15" x 15"), 54cm x 54cm (21" x 21") and 76cm x 76cm (30" x 30"). The Ezybox hotshoe folds flat for easy storage and can be assembled in a matter of minutes. The inner and outer diffusers, which when used together, produces a two stop light loss. There are also a number of accessories available including extending handles, a tilthead bracket and creative diffusers.

The Ezybox Hotshoe Softbox is not designed for use with studio flash heads.



Removable inner + outer diffusers



Features and Benefits
▶ Softbox for Hotshoe flash
▶ Adjustable bracket for different sized flash guns
▶ Operates as a coldshoe
▶ Folds flat
▶ Assembled in a few minutes
▶ Ideal for location use



Without Ezybox Hotshoe



With Ezybox Hotshoe

Specifications						
Ezybox Hotshoe	A	B	C	D	E	Code
Ezybox Hotshoe Small*	46cm (18")	46cm (18")	38cm (15")	38cm (15")	35cm (14")	LL LS2438
Ezybox Hotshoe Medium*	63cm (25")	63cm (25")	54cm (21")	54cm (21")	45cm (17.5")	LL LS2462
Ezybox Hotshoe Large*	90cm (35.5")	90cm (35.5")	76cm (30")	76cm (30")	77cm (30")	LL LS2480

*Includes Ezybox Hotshoe Bracket

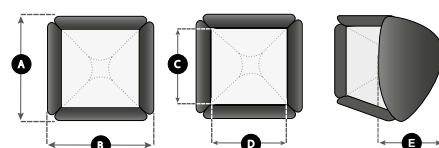

Ezybox Hotshoe Kits



Specifications

Ezybox Hotshoe Kits		
	Size	Code
Ezybox Hotshoe Kit small	38cm x 38cm (15" x 15")	LL LS2470
Ezybox Hotshoe Kit medium	54cm x 54cm (21" x 21")	LL LS2471
Ezybox Hotshoe Kit large	76cm x 76cm (30" x 30")	LL LS2472



Kit includes: Ezybox Hotshoe with bracket (LL LS2414), four section stand, tiltthead spigot (LL LA2401), extending handle (LL LS2400), padded shoulder bag and softbox carry case.

Tiltthead Spigot LL LA2401

Ezybox Hotshoe Accessories



Elinchrom Quadra speeding ring LL LS2362Q



Ezybox Hotshoe Bracket LL LS2414



Ezybox Hotshoe Creative Diffusers LL LS2469



Elinchrom Quadra speeding fit to Ezybox Hotshoe



Ezybox Hotshoe Bracket fit to Ezybox Hotshoe Softbox



Fabric Grid for Ezybox Hotshoe Softboxes LL LS2462 LL LS2480

Specifications

Ezybox Hotshoe Accessories		Code
Fabric Grid for LL LS2462 Ezybox Hotshoe Medium 54cm (21")		LL LS2962
Fabric Grid for LL LS2480 Ezybox Hotshoe Large 76cm (30")		LL LS2980
Ezybox Hotshoe Bracket (with standard flash mount)		LL LS2414
Elinchrom Quadra Speedring		LL LS2362Q
Set of three Creative Diffusers for the 54cm Ezybox Hotshoe Medium (LL LS2462)		LL LS2469

Multi-fit Softboxes

Ezybox Pro PATENT PENDING

Ezybox Pro is a range of unique fast fit softboxes which can be used with traditional studio flash, battery operated flashguns, the Elinchrom Ranger Quadra RX range and Profoto A1 and B2. The softboxes feature a unique softbox frame which fits directly to our Ezybox Pro Strip, Ezybox Pro Square, Ezybox Pro Octa and Ezybox Pro Switch softboxes. Depending on your chosen light source, a choice of adapters can then be used to link the light source to the softbox frame. So, rather than buying different softboxes for every light you own the Ezybox Pro now offers a true 'one system fits all' solution.

Features and Benefits

- ▶ Multi light system bracket
- ▶ Compatible with all seven Ezybox Pro softboxes
- ▶ Also works with umbrellas when using flashguns
- ▶ Speedlight Bracket ships with Tilthead Spigot (LL LA2401) and two way trigger cable



The Ezybox Pro Softbox Frame



Ezybox Pro Speedlight bracket with softbox frame



With flashguns and receiver



With studio flash



With Elinchrom Quadra



With flashguns and umbrella



With Profoto A1



With Profoto B2

Ezybox Pro - Configuration Chart

Step 1

Select softbox shape



Ezybox Pro	Code
Octa - Medium	LL LS2720P
Octa - Large	LL LS2721P

Ezybox Pro	Code
Square - Small	LL LS2710P
Square - Medium	LL LS2711P
Square - Large	LL LS2712P

Ezybox Pro	Code
Pro Switch - Large	LL LS2730P
Switch - XLarge	LL LS2731P

Ezybox Pro	Code
Strip 150cm x 30cm	LL LS3030

Step 2

Select your light source*



For studio flash, you will require a compatible Ezybox Pro Speedring for your system.



For speedlight, you will require the Ezybox Pro Speedlight Bracket.



For Elinchrom Quadra and Profoto B2, you will require the Ezybox Pro Speedlight Bracket plus the Quadra/Profoto Spigot.

Step 3

Select the correct connector



	Code
Bron	LL LS2350N
Bowens	LL LS2351N
Elinchrom	LL LS2352N
Balcar	LL LS2353N
Profoto	LL LS2354N



	Code
Ezybox Pro Speedlight Bracket**	LL LS2701

**Includes 2 way 3.5 jack, PC sync cable and tilthead spigot LL LS2401

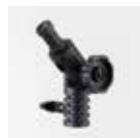

	Code
Ezybox Pro Speedlight Bracket	LL LS2701
Quadra/Profoto spigot	LL LS2705

* Light source not included

Multi-fit Softboxes

Ezybox Pro Strip



The Ezybox Pro is the world's first softbox designed to fit studio flash, battery operated flashguns, the Elinchrom Ranger Quadra RX and the Profoto A1 and B2. Designed to meet the demands of modern day photographers who shoot with studio flash and battery flash, the Ezybox Pro enables them to carry one softbox, which fits all their lighting kit and switch from one to the other using simple connectors, without making any adjustments to the softbox itself.

The Ezybox Pro Strip features a unique patent pending design, boasting an ultra-fast assembly time. The Ezybox Strip is built around an innovative collapsible framework, which remains attached at all times to the unique Ezybox Pro frame, the interface for the many different compatible light sources. The softbox fabric also remains attached to the framework and simply slides along the structure once assembled and clips into position at both ends. The 28.5cm x 147cm (11" x 58") softbox offers a 5:1 strip proportion, and includes an inner and outer diffuser which when used together offer a 2 stop light loss. The softbox can be used in the vertical and horizontal position. For added control and creativity the Ezybox Pro Strip also comes with a fabric grid which simply fits inside the recessed outer edge.

Rapid assembly, multiple light source compatibility and all the benefits of strip box style lighting.



Features and Benefits

- ▶ Unique patent pending design
- ▶ Can be used with studio flash, battery operated flash guns, Elinchrom Quadra and Profoto A1/B2
- ▶ Rapid assembly time
- ▶ Includes grid



Shot without key light to show effect of Ezybox Pro Strip

Connections	Code
Ezybox Pro Speedlight Bracket*	LL LS2701
Elinchrom Quadra/Profoto Spigot	LL LS2705
Ezybox Pro Speedring Plate (Bron)	LL LS2350N
Ezybox Pro Speedring Plate (Bowens)	LL LS2351N
Ezybox Pro Speedring Plate (Elinchrom)	LL LS2352N
Ezybox Pro Speedring Plate (Balcar)	LL LS2353N
Ezybox Pro Speedring Plate (Profoto)	LL LS2354N

*Includes Umbrella Holder, Tilthead Spigot (LL LA2401) and two way trigger cable

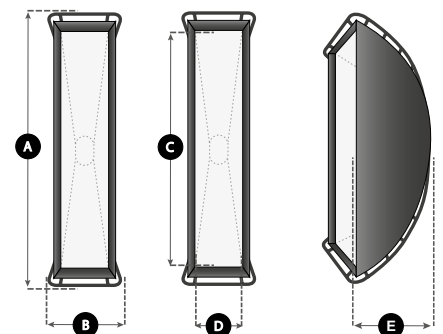

Specifications

Ezybox Pro Strip	A	B	C	D	E	Code
Ezybox Pro Strip	160cm (63")	28.5cm (11")	147cm (58")	25cm (10")	162.5cm (64")	LL LS3030

Multi-fit Softboxes

Ezybox Pro - Square

The Ezybox Pro is the world's first softbox designed to fit studio flash, battery operated flashguns, the Elinchrom Ranger Quadra RX and Profoto A1 and B2. Designed to meet the demands of modern day photographers who shoot with studio flash and battery flash, the Ezybox Pro enables them to carry one softbox which fits all their lighting kit and switch from one to the other using simple connectors, without making any adjustments to the softbox itself.

The Ezybox Pro Square softbox is our lightest softbox ever. Fast to assemble, the softbox simply pops open and is secured using two support rods and our unique Ezybox Pro softbox frame. The Ezybox Pro Square is available in three sizes - small, medium and large (see below for measurements) and feature inner and outer diffusers which when used together, produces a 2 stop light loss and simply requires the correct connection kit depending on your chosen light source(s).



Use with Elinchrom Quadra



Use with Studio Flash

Features and Benefits

- ▶ Unique world's first design
- ▶ Can be used with studio flash, battery operated flashguns, Elinchrom Quadra and Profoto A1 and B2
- ▶ Extremely lightweight and sturdy
- ▶ Optional grids available

Fabric Grids	Code
Fabric grids for Ezybox Pro Square - Small	LL LS2950
Fabric grids for Ezybox Pro Square - Medium	LL LS2951
Fabric grids for Ezybox Pro Square - Large	LL LS2952
Connections	Code
Ezybox Pro Speedlight Bracket*	LL LS2701
Elinchrom Quadra/Profoto Spigot	LL LS2705
Ezybox Pro Speedring Plate (Bron)	LL LS2350N
Ezybox Pro Speedring Plate (Bowens)	LL LS2351N
Ezybox Pro Speedring Plate (Elinchrom)	LL LS2352N
Ezybox Pro Speedring Plate (Balcar)	LL LS2353N
Ezybox Pro Speedring Plate (Profoto)	LL LS2354N

*Includes Umbrella Holder, Tilthead Spigot (LL LA2401) and two way trigger cable

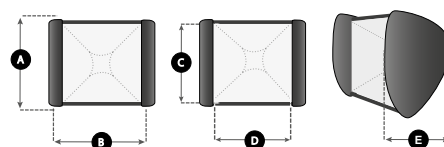

Specifications

Ezybox Pro Square	A	B	C	D	E	Code
Ezybox Pro Square - Small	50cm (20")	64cm (25")	45cm (18")	45cm (18")	34cm (13.5")	LL LS2710P
Ezybox Pro Square - Medium	64cm (25")	76cm (30")	60cm (24")	60cm (24")	40cm (16")	LL LS2711P
Ezybox Pro Square - Large	94cm (37")	120cm (47")	90cm (35.5")	90cm (35.5")	54cm (21")	LL LS2712P

Multi-fit Softboxes

Ezybox Pro - Octa

The Ezybox Pro is the world's first softbox designed to fit studio flash, battery operated flashguns, the Elinchrom Ranger Quadra RX and Profoto A1 and B2. Designed to meet the demands of modern day photographers who shoot with studio flash and battery flash, the Ezybox Pro enables them to carry one softbox which fits all their lighting kit and switch from one to the other using simple connectors, without making any adjustments to the softbox itself.

The Ezybox Pro Octa softbox is our lightest Octa ever. Fast to assemble, the softbox simply pops open and is secured using four support rods and our unique Ezybox Pro softbox frame. The Ezybox Pro Octa is available in two sizes - medium and large (see below for measurements) and feature inner and outer diffusers which when used together, produces a 2 stop light loss and simply requires the correct connection kit depending on your chosen light source(s).

Save time and money with the Ezybox Pro Octa softbox.



Features and Benefits

- ▶ Unique world's first design
- ▶ Can be used with studio flash, battery operated flashguns, Elinchrom Quadra and Profoto A1 and B2
- ▶ Extremely lightweight and sturdy
- ▶ Optional grids available
- ▶ Octagonal catchlights in the eyes



Frame included with softbox



Fabric Grids	Code
Fabric grids for Ezybox Pro Octa- Medium	LL LS2953
Fabric grids for Ezybox Pro Octa- Large	LL LS2954
Connections	Code
Ezybox Pro Speedlight Bracket*	LL LS2701
Elinchrom Quadra/Profoto Spigot	LL LS2705
Ezybox Pro Speedring Plate (Bron)	LL LS2350N
Ezybox Pro Speedring Plate (Bowens)	LL LS2351N
Ezybox Pro Speedring Plate (Elinchrom)	LL LS2352N
Ezybox Pro Speedring Plate (Balcar)	LL LS2353N
Ezybox Pro Speedring Plate (Profoto)	LL LS2354N

*Includes Umbrella Holder, Tiltthead Spigot (LL LA2401) and two way trigger cable

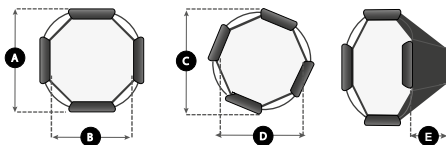

Specifications

Ezybox Pro Octa	A	B	C	D	E	Code
Ezybox Pro - Octa Medium	97cm (38")	80cm (31.5")	99cm (39")	88cm (35")	52cm (20.5")	LL LS2720P
Ezybox Pro - Octa Large	117cm (46")	102cm (40")	120cm (47")	112cm (44")	66cm (26")	LL LS2721P

Multi-fit Softboxes

Ezybox Pro - Switch PATENT PENDING

The Ezybox Pro is the world's first softbox designed to fit studio flash, battery operated flashguns, the Elinchrom Ranger Quadra RX and Profoto A1 and B2. Designed to meet the demands of modern day photographers who shoot with studio flash and battery flash, the Ezybox Pro enables them to carry one softbox which fits all their lighting kit and switch from one to the other using simple connectors, without making any adjustments to the softbox itself.

The Ezybox Pro Switch is the world's first softbox which can be switched from one size to another. Fast to assemble, the softbox simply pops open and is secured using two support rods and our unique Ezybox Pro softbox frame. To adjust the format, a simple zip system is used to expand or retract the width of two of the side panels. The Ezybox Pro Switch is available in two sizes - large and extra large (see below for measurements) and feature inner and outer diffusers which when used together, produces a 2 stop light loss and simply require the correct connection kit depending on your chosen light source(s).

Two softboxes in one!



Features and Benefits

- ▶ Unique world's first design
- ▶ Can be used with studio flash, battery operated flashguns, Elinchrom Quadra and Profoto A1 and B2
- ▶ Extremely lightweight and sturdy
- ▶ Optional grids available



Fabric Grids	Code
Fabric grids for Ezybox Pro Switch Large (Narrow)	LL LS2955
Fabric grids for Ezybox Pro Switch Large (Wide)	LL LS2952
Fabric grids for Ezybox Pro Switch XLarge (Narrow)	LL LS2956
Fabric grids for Ezybox Pro Switch XLarge (Wide)	LL LS2957
Connections	Code
Ezybox Pro Speedlight Bracket*	LL LS2701
Elinchrom Quadra/Profoto Spigot	LL LS2705
Ezybox Pro Speedring Plate (Bron)	LL LS2350N
Ezybox Pro Speedring Plate (Bowens)	LL LS2351N
Ezybox Pro Speedring Plate (Elinchrom)	LL LS2352N
Ezybox Pro Speedring Plate (Balcar)	LL LS2353N
Ezybox Pro Speedring Plate (Profoto)	LL LS2354N

*Includes Umbrella Holder, Tiltthead Spigot (LL LA2401) and two way trigger cable

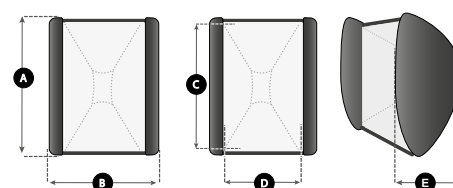

Specifications

Ezybox Pro Switch	A	B	C	D	E	Code
Ezybox Pro - Switch Large (Narrow)	94cm (37")	65cm (25.5")	89cm (35")	44cm (17")	63cm (25")	LL LS2730P
	94cm (37")	125cm (49")	89cm (35")	89cm (35")	42cm (16.5")	
Ezybox Pro - Switch Extra Large (Narrow)	121cm (48")	64cm (25")	117cm (46")	44cm (17")	61cm (24")	LL LS2731P
	121cm (48")	116cm (46")	117cm (46")	90cm (35.5")	43cm (17")	

Flashgun Modifiers

Strobo

The Strobo is a compact and simple to use creative light modifying system for battery operated flashguns. The Strobo is available in various kit configurations using two different flash gun attachment methods, one which fits directly onto a flashgun (LL LS2616, LL LS2605 & LL LS2606) and the other which utilises the highly successful Ezybox Hotshoe Bracket (LL LS2617). Each version incorporates clever magnetic connection points which allow a range of accessories to simply snap into place in front of the flashgun, ready to modify the raw light as it leaves the gun. The range of modifiers include honeycombs, gels, gobos, a snoot and barn doors. The modifiers can be used individually or in combination with each other.

Features and Benefits

- ▶ Creative light modifiers for flashguns
- ▶ Studio lighting effects for flashguns
- ▶ Unique magnetic connecting system
- ▶ Fits neatly in your camera bag



2 x Flashguns with Strobo Honeycomb on one and Strobo red gel on the other



1 x Flashgun with Strobo Honeycomb



Flashgun Strobo System

How do you want to attach your Strobo System?



Direct to Flashgun



Direct to Hotshoe Bracket

Lastolite™ Strobo



Direct to Flashgun LL LS2616



Gel Starter Kit Direct to Flashgun LL LS2605



Honeycomb Starter Kit Direct to Flashgun LL LS2606



Direct to Hotshoe Bracket LL LS2617

Strobo Accessories for Direct to Flash & Direct to Bracket



Direct to Flashgun Bracket LL LS2601



Ezybox Hotshoe Bracket Adaptor LL LS2611



Ezybox Hotshoe Bracket LL LS2414



Gel Set LL LS2604



Honeycomb Set LL LS2602



Gel Holders LL LS2603



Collapsible Snoot LL LS2619



Gobo LL LS2625



Barn Doors LL LS2620

Flashgun Modifiers

Strobo Kit – Direct to Bracket



LL LS2617



Specifications

Strobo Kit	Code
Strobo Kit - Direct to Bracket	LL LS2617

Kit Contents

- 1x Ezybox Hotshoe Bracket (LL LS2414)
- 1x Ezybox Hotshoe Bracket Adaptor
- 2x Honeycomb Grids 3/8" (9mm) and 1/4" (6mm)
- 2x Gel Holders
- 1x Gel Set*



Honeycomb



Ezybox Hotshoe Bracket Adaptor



Gel set



Slide in gel holder

Strobo Kit – Direct to Flashgun



Honeycomb Starter Kit LL LS2606

Specifications

Strobo Kit	Code
Strobo Kit - Direct to Flashgun	LL LS2616

Kit Contents

- 1x Direct to Flashgun Bracket
- 2x Honeycomb Grids 3/8" (9mm) and 1/4" (6mm)
- 2x Gel Holders
- 1x Gel Set*

Strobo Gel Starter Kit

Strobo Gel Starter Kit - Direct to Flashgun	Code
Strobo Gel Starter Kit - Direct to Flashgun	LL LS2605

Kit Contents

- 1x Strobo Direct to Flashgun bracket
- 1x Gel Holder
- 1x Gel Set*

Strobo Honeycomb Starter Kit

Strobo Honeycomb Starter Kit - Direct to Flashgun	Code
Strobo Honeycomb Starter Kit - Direct to Flashgun	LL LS2606

Kit Contents

- 1x Strobo Direct to Flashgun bracket
- 1x Honeycomb Grid 3/8" (9mm)

*Gel Set Contents:

- 1x Set of 3 Warming Gels - Full, 1/2 and 1/4 CTO
 - 1x Set of 3 Cooling Gels - Full, 1/2 and 1/4 CTB
 - 1x Set of 4 Coloured Gels - Red, Yellow, Blue & Green
 - 1x Neutral Density 0.6 - 2 Stop Gel
 - 1x Frosted 1 Stop Diffuser Gel
- All kit contents are available separately (see page 35)



Gel holder



Honeycomb



Strobo Gobo

The Strobo Gobo kit allows you to create stunning lighting and background effects using your battery operated flashguns without the need to keep moving locations. The Gobo works with your chosen Strobo Bracket - LL LS2414 + LL LS2611 or LL LS2601. Simply attach the Gobo to your existing bracket and slide in your chosen Gobo mask. The kit comes with two Gobo masks as standard; an arched window and a dappled foliage effect. A range of alternative Gobo masks are available separately. The Gobo holder also takes traditional size B Gobos (86mm). There is even an option to create a slightly 'out of focus' effect.



Features and Benefits

- ▶ Create different background effects without moving location
- ▶ A range of Gobo masks are available
- ▶ Can be used in conjunction with Strobo gels
- ▶ Also take standard size B Gobos (86mm)

Specifications

Strobo Gobo	Code
Strobo Gobo**	LL LS2625
Gobo Set - Nature*	LL LS2613
Gobo Set - Architectural*	LL LS2612

*Contains 3 different Gobo's

**Requires Ezybox Hotshoe Bracket Adapter LL LS2611 for use with the Ezybox Hotshoe Bracket LL LS2414

Strobo Collapsible Snoot

The Strobo collapsible snoot allows you to take maximum control of the light from your battery operated flashguns. Simply attach the snoot directly to your chosen Strobo bracket - LL LS2414 + LL LS2611 or LL LS2601 to create a small concentrated pool of light, ideal as a hair light or to illuminate a small part of your subject. The Strobo snoot instantly transforms the harsh light from your flashgun into an extremely creative light which traditionally could only be achieved using studio flash. For added creativity the Strobo snoot can also be used in conjunction with the Strobo gel system.



Without Strobo Snoot



With Strobo Snoot

Features and Benefits

- ▶ Unique collapsible design for easy storage
- ▶ Create a controlled pool of concentrated light
- ▶ Can be used in conjunction with Strobo gels
- ▶ Supplied with storage pouch

Specifications

Strobo Collapsible Snoot	Code
Strobo Collapsible Snoot*	LL LS2619

*Requires Ezybox Hotshoe Bracket Adapter LL LS2611 for use with the Ezybox Hotshoe Bracket LL LS2414



Strobo Accessories



Barn Doors (bracket and gel holder not included)

Specifications

Strobo Accessories	Code
Barn Doors for Strobo	LL LS2620
Honeycomb Set 3/8" (9mm) and 1/4" (6mm)	LL LS2602
Gel Holder Set (x2)	LL LS2603
Gel Set*	LL LS2604
Strobo Ezybox Hotshoe Bracket Adaptor	LL LS2611
Strobo Direct to Flashgun Bracket	LL LS2601
Ezybox Hotshoe Bracket	LL LS2414

*Gel Set Contents:
 1x Set of 3 Warming Gels - Full, 1/2 and 1/4 CTO
 1x Set of 3 Cooling Gels - Full, 1/2 and 1/4 CTB
 1x Set of 4 Coloured Gels - Red, Yellow, Blue & Green
 1x Neutral Density 0.6 - 2 Stop Gel
 1x Frosted 1 Stop Diffuser Gel



Gel Set LL LS2604



Ezybox Hotshoe Bracket Adaptor LL LS2611



Ezybox Hotshoe Bracket LL LS2414



Strobo Direct to Flashgun Bracket LL LS2601



Honeycomb Set LL LS2602



Gel Holders LL LS2603

Flashgun Brackets & Accessories

TriFlash Shoe Lock

The TriFlash Shoe Lock is a unique bracket which allows photographers to attach up to three flashguns onto one light stand. The bracket features an umbrella socket so the gun(s) can be used with or without a shoot through or reflective umbrella. The adjustable 'screw locking' shoe mounts offer an additional locking mechanism to work alongside the built in method used on a flashgun. Whether you are looking for increased overall power or a quicker recycling time with the guns on a lower power, the TriFlash Shoe Lock will be a valuable addition to your kit.



Features and Benefits

- ▶ Attach up to three flashguns
- ▶ Screw locking
- ▶ Can be mounted onto a standard brass spigot
- ▶ Umbrella socket

Specifications

TriFlash Shoe Lock	Code
TriFlash Shoe Lock	LL LA2423



Quad Bracket

The ultimate flashgun bracket. Whether you are looking for more power to freeze the action or a faster recycling time from your flashguns the Quad Bracket is the perfect solution. Simply attach up to 4 flashguns to the bracket, then attach one of our Ezybox Pro Octa softboxes or umbrellas to create a beautifully diffused light.



Features and Benefits

- ▶ Attach up to 4 flashguns
- ▶ Strong robust design
- ▶ Can be used with the Ezybox Pro Octa softboxes or umbrellas
- ▶ Includes PC and 3.5mm jack cables

Specifications

	Code
Ezybox Pro Octa Quad Bracket*	LL LS2530
Quad Bracket**	LL LS2535

* Compatible with Ezybox Pro Octa

** For use with flashguns only or flashguns with an umbrella. Cannot be used with Ezybox Pro Octa softboxes.

LL LS2530 for Umbrellas and Softboxes

Quad Bracket for umbrellas LL LS2535

LL LS2535 with Mega Umbrella

Joe McNally Signature Range

Joe McNally

Joe McNally is an internationally acclaimed photographer whose career has spanned 30 years and included assignments in over 50 countries. He has shot cover stories for TIME, Newsweek, Fortune, New York, Entertainment Weekly, The New York Times Sunday Magazine, and Men's Journal. He has been a contract photographer for Sports Illustrated, a staff photographer at LIFE, and, currently, an ongoing 23-year contributor to the National Geographic. Joe was listed by American Photo as one of the 100 Most Important People in Photography and described by the magazine as "perhaps the most versatile photojournalist working today". He has been honored as a member of Kodak- PDN Legends Online, as well as being a Nikon Legend Behind the Lens. In 2010, he was voted as one of the 30 most influential photographers of the decade in an industry- wide Photo District News survey. Joe is proud to be recently named to the Nikon Ambassador program. He also received a "Top Blog Award" by Resource Magazine, in addition to a recent accolade as one of "The Top 5 Most Socially Influential Photographers" by EyeFi.



Joe McNally Ezybox Speed-Lite 2 Plus

PATENT PENDING

Based on the original Lastolite Ezybox Speed-Lite 2 (page 21) the Joe McNally 'plus' version features Joe's preferred white interior for a 'softer / creamier' look. It also includes a removable internal diffuser and a deep recessed outer diffuser to reduce any unwanted 'spill' of light. The 22cm x 22cm (8.5" x 8.5") mini softbox features a unique, design patented, folding mechanism with an innovative twist lock silicon strap for a quick and secure attachment to your flashgun, making it an ultra-portable, quick assembly softbox. Also compatible with Strobe magnetic honeycombs and gels.

An optional diffused grid (45mm depth) is also available for greater control of the light.

Features and Benefits

- ▶ Assembled in seconds
- ▶ Compatible with Lastolite by Manfrotto Strobe honeycombs and gels

Specifications

Joe McNally Ezybox Speed-Lite 2 Plus	Code
Joe McNally Ezybox Speed-Lite 2 Plus 22cm x 22cm (8.5" x 8.5")	LL LS2430JM
Fabric Grid	LL LS2436



Joe McNally Signature Range

Joe McNally Ezybox

The Joe McNally Ezybox Hotshoe is a new addition to our highly acclaimed softbox range for battery operated flashguns. Unlike our existing range of Ezybox Hotshoe softboxes, the Joe McNally version features a white interior rather than silver which offers a slightly softer creamier level of diffusion. As with our other softboxes this version features two removable diffusion layers and is compatible with our softbox accessories such as Grids and the Creative Mask Strips.



Features and Benefits

- ▶ Adjustable bracket for different sized flashguns
- ▶ Inner and outer diffuser
- ▶ White interior

Specifications

Joe McNally Ezybox Hotshoe	Code
Joe McNally White Ezybox Hotshoe 54cm x 54cm (21" x 21")	LL LR2462JM



Double diffusion layer

Joe McNally 4 in 1 Umbrella

The Joe McNally 4 in 1 Umbrella is the largest 'mid-sized' umbrella available, 140cm (55") open. It features four different lighting options (silver bounce, white bounce, translucent shoot through and translucent shoot through with square mask). The Joe McNally 4 in 1 Umbrella offers un-rivalled versatility and could be the only umbrella you will ever need. Large enough to light a full length portrait, the 4 in 1 also offers the photographer the options to create 'softbox' type catch-lights in the eyes with the translucent shoot through with mask.



Features and Benefits

- ▶ White bounce
- ▶ Silver bounce
- ▶ Shoot through
- ▶ Shoot through with square mask

Specifications

Joe McNally 4 in 1 Umbrella	A	B	C	D	Code
Joe McNally 4 in 1 Umbrella	178cm (70")	93cm (36.5")	130cm (51")	140cm (55")	LL LU5038JM

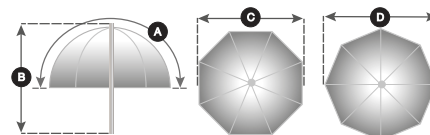

Joe McNally Signature Range

Joe McNally TriFlash

The Joe McNally TriFlash is the latest addition to our successful TriFlash range. Joe's version of this product features unique rotating shoe mounts which allow him to position his flashguns so that the IR receiver on the guns are always pointing to camera position, ensuring reliable off camera flash triggering, particularly in bright conditions where Joe sometimes finds IR triggering difficult.



Features and Benefits

- ▶ Attach up to three flashguns
- ▶ Rotating shoe mounts
- ▶ Screw locking

Specifications

Joe McNally Rotating TriFlash	Code
Joe McNally Rotating Locking TriFlash Tiltthead	LL LR2457JM



Joe McNally Skylite Rapid with Masks

The Joe McNally Skylite Rapid with Masks is a 1.1m x 1.1m (3'6" x 3'6") 2 stop translucent panel featuring the unique clip-on cover from the Lastolite Skylite Rapid system. Featuring removable mask strips which attach directly to the cover, the photographer has full control on how to shape the light; from the full 1.1 x 1.1m (3'6" x 3'6") to 1cm x 90cm (0.4" x 35.5") or a 30cm x 60cm (12" x 23.5") rectangle, the possibility is endless. This product is ideal for diffusing the light from three speedlights fitted to a Joe McNally TriFlash. The whole product is supplied in a handy carry bag for maximum portability.



Features and Benefits

- ▶ Rigid aluminium frame
- ▶ Seven mask strips
- ▶ Griphead included
- ▶ Quick and easy to assemble

Specifications

Joe McNally Skylite Rapid with Masks	Code
Joe McNally Skylite Rapid with Masks	LL LR81146JM



Joe McNally Signature Range

Joe McNally UpLite

The Joe McNally UpLite features two 90cm x 120cm (3' x 4') double sided reflectors (Silver / White and Sunlite / Soft Silver) plus a 90cm x 120cm (3' x 4') 2 stop diffuser panel. Any combination of these panels can be paired up to form a floor level bounce reflector, and can be adjusted to alter the angle of the panels from 30 degrees to 80 degrees. Joe will sometimes replace the top reflector panel with the diffuser, and shoot one or more of his flashguns through the panel, giving him a fully controllable diffused fill light. A waterproof shower cap protects the base when used outdoors whatever the weather.



Features and Benefits

- ▶ Self supporting reflector/diffuser panels
- ▶ 30 to 80 degree positions
- ▶ Ideal for outdoor use
- ▶ Waterproof base bottle top

Specifications

Joe McNally UpLite Kit	Code
Joe McNally UpLite Kit	LL LR3497JM

Kit contains - 2 x reflector panels, 1 x diffuser panel, 1 x extending support, 1 x waterproof bottle top.



Joe McNally Ironworks Background

This background offers a distinctive vintage, industrial style look, selected by Joe himself from an original painted artwork. Great for portraits, fashion and product photography, this versatile reversible background provides a timeless hand painted backdrop look that subtly complements the chosen subject.

The Ironworks background features the same textural design on both sides, but each with different colour characteristics. The first side is a blend of greys and browns with subtle hints of blue, whilst the reverse surface is a monochrome version offering a broad range of grey tones. Two great backgrounds in one with a collapsible, pop up construction that provides the photographer with a truly portable hand painted scroll effect background.



Features and Benefits

- ▶ Reversible
- ▶ Collapsible to a third of its original size
- ▶ Carry bag included
- ▶ Compatible with the Magnetic Background Support (LL LB1120)

Specifications

Joe McNally Ironworks Collapsible Background	1.5m x 2.1m (5' x 7')
1.5m x 2.1m (5' x 7')	LL LB5750JM

Some camera sensors may interpret the colours used on our printed backgrounds differently.



Flashgun Brackets & Accessories

Off Camera Cords for Flashguns

Extension cords to enable the photographer to position their battery operated flashguns up to 3m (9'9") away from the camera. Available in Canon and Nikon versions.



Features and Benefits

- ▶ Single shoe mount
- ▶ Retains all TTL metering
- ▶ Position gun up to 3m (10') from the camera
- ▶ Available to fit Canon and Nikon

Specifications

Off Camera Cords 3m	Code
Single eTTL Canon Pro 3m (10')	LL LS2424
Single iTTL Nikon Pro 3m (10')	LL LS2425

Brolly Grip

The ultimate light modifier for the photographer who needs to be mobile. The Brolly Grip is a unique hand held bracket which supports the flashgun in a horizontal position along the shaft of an umbrella. A 50cm (20") translucent umbrella is included in the kit to create a compact, quick to assemble 'shoot through' solution for photographers.



Features and Benefits

- ▶ Flashgun close to umbrella shaft
- ▶ Hand held or used on a stand
- ▶ Suitable for 8mm (0.3") and 10mm (0.4") shaft

Specifications

Brolly Grip	Code
Brolly Grip Kit with Translucent Umbrella	LL LU2126

White Translucent 1 Stop



Umbrellas

8:1 Umbrella

The 8:1 is the ultimate umbrella offering more versatility than any other umbrella on the market. The different combinations are as follows:

- White bounce
- Silver bounce
- Shoot through
- Shoot through with square mask
- Shoot through box
- Shoot through box with square mask
- Umbrella box (bounce) with silver interior
- Umbrella box (bounce) with white interior

The 8:1 can be used with studio flash and battery operated flashguns.

Features and Benefits

- ▶ Umbrella and softbox functionality
- ▶ 8mm (0.3") shaft
- ▶ Includes carry pouch for storage when not in use
- ▶ Fibreglass frame



White Bounce



Silver Bounce



Umbrella Box (Bounce) with silver interior



Shoot Through



Shoot Through with square mask



Umbrella Box (Bounce) with white interior



Shoot Through Box



Shoot Through Box with square mask

Silver



White Translucent
1 Stop (shoot through)



White Translucent
2 Stop (umbrella box)

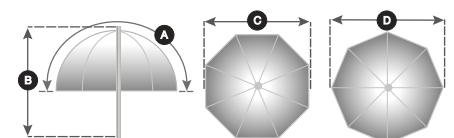
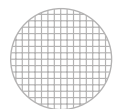

Specifications					
8:1 Umbrella	A	B	C	D	Code
8:1 Umbrella	112cm (44")	71cm (28")	94.5cm (37")	101.5cm (40")	LL LU4538F

Umbrellas

Umbrellas - Dual



Specifications							
Colour	A	B	C	D	Colour Temp.	Light Loss	Code
White Bounce / Translucent Small	92.5cm (36½")	61cm (24")	78cm (31")	84.5cm (33")	5600k 5450k	-0.3f (bounce) -0.6f (shoot through)	LL LU3223F
White Bounce / Translucent Large	112cm (44")	71cm (28")	94.5cm (37")	101.5cm (40")	5600k 5450k	-0.3f (bounce) -0.6f (shoot through)	LL LU4523F

- Features and Benefits**
- ▶ Removable outer cover
 - ▶ Translucent shoot through
 - ▶ Translucent white bounce with silver behind
 - ▶ Umbrella spokes are concealed behind translucent fabric
 - ▶ 8mm (0.3") shaft

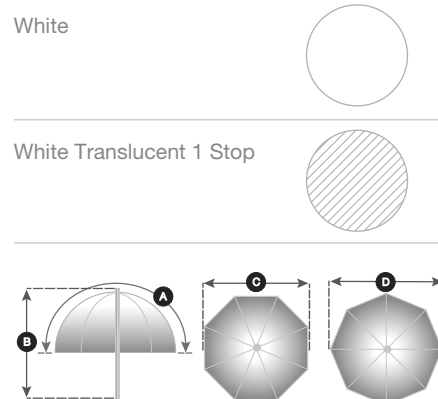

Umbrellas - All in One



Specifications							
Colour	A	B	C	D	Colour Temp.	Light Loss	Code
Silver/White Small	92.5cm (36½")	61cm (24")	78cm (31")	84.5cm (33")	5600k 5450k	-0.6f (shoot through) -0.2f (silver white bounce) -0.1f (white bounce) -0.2f (silver bounce)	LL LU3237F
Silver/White Large	112cm (44")	71cm (28")	94.5cm (37")	101.5cm (40")	5600k 5450k	-0.6f (shoot through) -0.2f (silver white bounce) -0.1f (white bounce) -0.2f (silver bounce)	LL LU4537F

- Features and Benefits**
- ▶ Removable covers
 - ▶ Translucent shoot through
 - ▶ Translucent white bounce
 - ▶ White bounce with silver behind
 - ▶ Silver bounce
 - ▶ 8mm (0.3") shaft

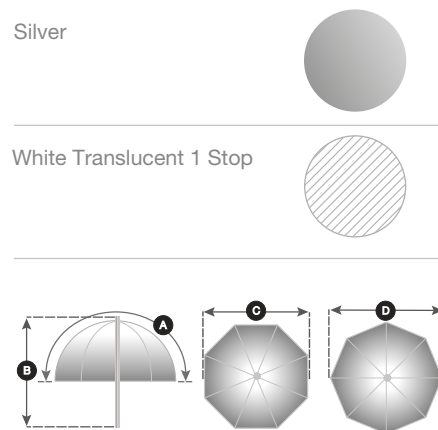

Umbrellas

Umbrellas - Essentials



Bounce PVC LL LU3212F / LL LU4512F



White Translucent LL LU3207F / LL LU4507F

Features and Benefits

- ▶ White translucent shoot through
- ▶ White PVC bounce
- ▶ Available in various sizes
- ▶ 8mm (0.3") shaft

White Translucent 1 Stop

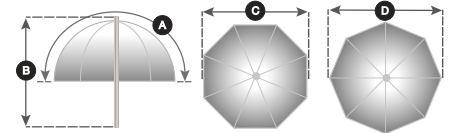

Specifications

Style	Colour	A	B	C	D	Colour Temp.	Light Loss	Code
Translucent	White	92.5cm (36½")	61cm (24")	78cm (31")	84.5cm (33")	5450k	-0.9f	LL LU3207F
Translucent	White	112cm (44")	71cm (28")	94.5cm (37")	101.5cm (40")	5450k	-0.7f	LL LU4507F
Bounce PVC	White	92.5cm (36½")	61cm (24")	78cm (31")	84.5cm (33")	5450k	-0.9f	LL LU3212F
Bounce PVC	White	112cm (44")	71cm (28")	94.5cm (37")	101.5cm (40")	5450k	-0.7f	LL LU4512F

Mega Umbrellas

The Mega umbrella is our largest umbrella featuring a removable cover. There are two models available, the first is a white translucent shoot through which creates a shallow parabolic for maximum spread and the second is a silver reflective surface which creates a deeper parabolic for a more focused spread of light. Each umbrella features a white fibreglass framework with an 8mm shaft diameter. The umbrella is also available as a kit which features the white shoot through and silver reflective covers.



Features and Benefits

- ▶ Removable covers
- ▶ White fibreglass framework
- ▶ 8mm (0.3") shaft
- ▶ Available as a silver bounce or translucent shoot through

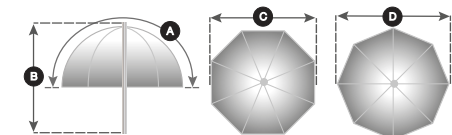

Specifications

Mega Umbrella	A	B	C	D	Code
Mega Umbrella - Translucent	220cm (86")	91cm (35")	181cm (71")	185cm (72")	LL LU7907F
Mega Umbrella - Silver Parabolic	220cm (86")	91cm (35")	157cm (61")	160cm (63")	LL LU7908F
Mega Umbrella Kit					LL LU7915F

Kit includes Silver Parabolic Umbrella and 1x translucent cover

Umbrellas

Trifold Umbrella

The ultimate compact shoot through umbrella for the photographer who needs to be mobile. Featuring a triple fold mechanism, the Trifold Umbrella folds down to an ultra-compact size, making it easy to slip into a camera bag. Great for using with compact flashguns.



Features and Benefits

- ▶ 10mm (0.4") shaft
- ▶ Lightweight and compact
- ▶ Ideal for use with flashguns

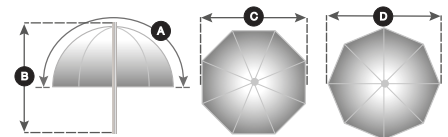

Specifications

Style	A	B	C	D	Code
Trifold Umbrella	112cm (44")	39cm (15")	89.5cm (35")	98cm (39")	LL LU2127

Umbrella Kits

The umbrella kit comes in two sizes featuring either a 84.5cm (33") or 101.5cm (40") Lastolite By Manfrotto All In One Umbrella (see page 44). The kit includes the Umbrella, four section stand, Hotshoe Tiltthead and padded shoulder bag. The All in One Umbrella can be used as a silver or white bounce, a silver and white bounce or shoot through.



Features and Benefits

- ▶ Truly portable solution
- ▶ All in one solution
- ▶ Includes a padded shoulder bag

Specifications

Style	A	B	C	D	Colour Temp.	Code
Umbrella Kit with LL LS2422 Tiltthead Shoe Lock	92.5cm (36½")	61cm (24")	78cm (31")	84.5cm (33")	5600k 5450k	LL LU2473F
Umbrella Kit with LL LS2422 Tiltthead Shoe Lock	112cm (44")	71cm (28")	94.5cm (37")	101.5cm (40")	5600k 5450k	LL LU2474F



Tiltthead Shoe Lock LL LA2422

Multi-fit Softboxes

MegaLite PATENTED

The bigger the softbox, the softer the light!

The MegaLite is a large 1.2 x 1.8m (4' x 6') portable softbox and silver reflective panel. The MegaLite can be used as a floor standing unit or in conjunction with the adjustable stand (with wheels) for ultimate adjustability. The stand enables the photographer to raise the softbox up to 105cm (42") from the floor and rotate the angle of the softbox/reflector from vertical to horizontal. The softbox can be lit with one or two studio flash heads (one on each side) depending on the output required. If using the softbox with the stand (LL LB6489) the heads attach directly onto the stand so they move with the softbox making positioning very quick and easy.

Features and Benefits	
▶	Portable 1.2 x 1.8m (4' x 6') softbox
▶	Folds to a third of its original size
▶	Silver reflector on rear surface
▶	Optional stand on wheels with vertical and rotational movements

Specifications	
MegaLite	Code
MegaLite softbox/reflector	LL LB6488
MegaLite Adjustable Stand with Wheels	LL LB6489



Using a traditional light stand



Using adjustable stand with wheels



Portable Backgrounds

Plain Background Swatches



Blue



Red



Grey



Pink



Purple



Black



White

Plain Collapsible Backgrounds

A range of collapsible, reversible, plain coloured backgrounds. In addition to the standard black, white and grey we now have a range of punchy vibrant colours for a more modern look to your portraits.

A simple solution for flat plain coloured backgrounds, a great way to get the seamless paper effect but in a collapsible portable format!



Features and Benefits

- ▶ Crease resistant
- ▶ Single colours
- ▶ Reversible
- ▶ Collapsible
- ▶ Ideal for passport, ID and corporate photos



Specifications

Plain Collapsible Backgrounds	Size	Code
Blue / Pink	1.8m x 2.15m (6' x 7')	LL LB6751
Red / Purple	1.8m x 2.15m (6' x 7')	LL LB6752
Black / White	1.5m x 1.8m (5' x 6')	LL LC5621
Black / White	1.8m x 2.15m (6' x 7')	LL LB5921
Black / White	1.8m x 2.75m (6' x 9')	LL LB6921
Black / White with train	1.8m x 2.15m (6' x 7')	LL LB6701
Black / Mid Grey	1.5m x 1.8m (5' x 6')	LL LB56GB
Black / Mid Grey	1.8m x 2.15m (6' x 7')	LL LB67GB
White / Mid Grey	1.5m x 1.8m (5' x 6')	LL LB56GW
White / Mid Grey	1.8m x 2.15m (6' x 7')	LL LB67GW

Urban Background Swatches



Red Brick / Grey Stone LL LB5711



Corrugated / Metal LL LB5712



Rusty Metal / Plaster Wall LL LB5713



Red Brick / Grey Stone LL LB5711



Corrugated / Metal LL LB5712



Rusty Metal / Plaster Wall LL LB5713



Distressed Paper / Graffiti LL LB5714



Derelict Wall / Wooden Fence LL LB5715



Shutter / Distressed Door LL LB5717



Distressed Paper / Graffiti LL LB5714



Derelict Wall / Wooden Fence LL LB5715



Shutter / Distressed Door LL LB5717



Tarnished Metal / Container LL LB5718



Smoke / Concrete LL LB5745

Specifications

Urban Collapsible Backgrounds		1.5m x 2.1m (5' x 7')
Red Brick / Grey Stone	LL LB5711	
Corrugated / Metal	LL LB5712	
Rusty Metal / Plaster Wall	LL LB5713	
Distressed Paper / Graffiti	LL LB5714	
Derelict Wall / Wooden Fence	LL LB5715	
Shutter / Distressed Door	LL LB5717	
Tarnished Metal / Container	LL LB5718	
Smoke / Concrete	LL LB5745	

Some camera sensors may interpret the colours used on our printed backgrounds differently.

Portable Backgrounds

Urban Collapsible Backgrounds

The urban collapsible backgrounds allow you to create the outdoor look in an instant whether you're in the studio or a client's home. Each double sided background has unique urban feel and can quickly add a new dimension to your portrait sittings. No longer will you have to find locations or be controlled by the weather.

Features and Benefits

- ▶ 16 different surfaces
- ▶ Reversible
- ▶ Create the location effect anywhere
- ▶ Collapsible to a third of its original size



Concrete LL LB5745

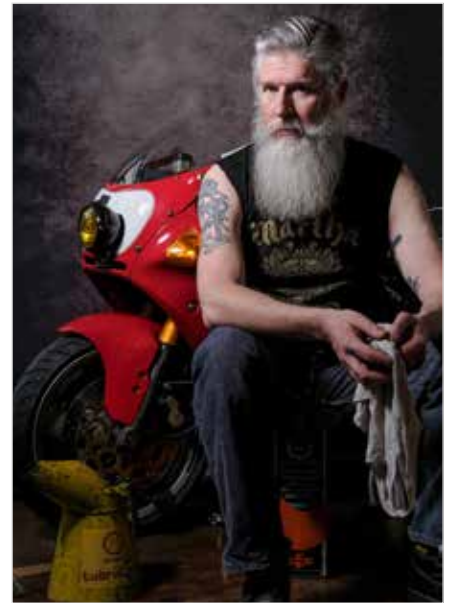

Smoke LL LB5745



Corrugated LL LB5712



Smoke LL LB5745



Rusty Metal LL LB5713



Container LL LB5718



Distressed Door LL LB5717



Derelict Wall LL LB5715

Portable Backgrounds

Perspective Background Swatches



Stone Steps / Winter Trees LL LB5740



Stone Archway / Grecian Steps LL LB5741



Evening Street / Ivy Archway LL LB5742

Perspective Backgrounds

Perspective backgrounds are a range of three double sided backgrounds offering inspirational scenic options. You can bring these beautiful scenes to life whatever the weather outdoors adding a new dimension to your portrait sittings.



- Features and Benefits**
- ▶ 6 different surfaces
 - ▶ Reversible
 - ▶ Create the location effect anywhere
 - ▶ Collapsible to a third of its original size



Specifications		
Perspective Backgrounds	Size	Code
Stone Steps / Winter Trees	1.5m x 2.1m (5' x 7')	LL LB5740
Stone Archway / Grecian Steps	1.5m x 2.1m (5' x 7')	LL LB5741
Evening Street / Ivy Archway	1.5m x 2.1m (5' x 7')	LL LB5742

Some camera sensors may interpret the colours used on our printed backgrounds differently.

Out of Focus Background Swatches



Summer Foliage / City Lights LL LB5730

Autumn Foliage / Seascape LL LB5731

Out of Focus Backgrounds

Want to create images with beautiful 'bokeh' and shoot at f8? With the Lastolite 'Out of Focus' backgrounds you can create that wonderful 'drop-focus' look whilst still shooting at the sharpest of apertures. Ideal for professionals or amateurs alike, these double sided 1.2m x 1.5m (4' x 5') collapsible backgrounds feature 'out of focus' scenes of a variety of locations. With Summer Foliage/City Lights or Autumn Foliage/Seascape to choose from there's a scene for any occasion. The backgrounds are easily transportable, folding to a third of their original size and are perfect for up to half length portraits.

Features and Benefits

- ▶ Four different reversible surfaces
- ▶ 'Drop focus' look
- ▶ Create the location effect anywhere
- ▶ Collapsible to a third of its original size



Specifications

Out of Focus Backgrounds	Size	Code
Summer Foliage / City Lights	1.2m x 1.5m (4' x 5')	LL LB5730
Autumn Foliage / Seascape	1.2m x 1.5m (4' x 5')	LL LB5731

Some camera sensors may interpret the colours used on our printed backgrounds differently.

Portable Backgrounds

Dyed Background Swatches



Florida



Washington



Wyoming



Maine



Dakota



Mississippi

Dyed Collapsible Reversible Backgrounds

This extensive range of collapsible backgrounds gives photographers the colours and patterns to express their creativity.



Features and Benefits

- ▶ Crease resistant fabric
- ▶ The ultimate location accessory
- ▶ Collapses to a third of its original size
- ▶ Ideal for portraits on location or in the studio
- ▶ Can be used for solo portraits or smaller groups
- ▶ Zip up bag
- ▶ Reversible
- ▶ Combine with the Magnetic Background Support LL LB1120 (page 63)



Specifications

Dyed Collapsible Reversible Backgrounds	Size	Code
Florida / Maine	1.5m x 1.8m (5' x 6')	LL LB56FM
Washington / Dakota	1.5m x 1.8m (5' x 6')	LL LB56WD
Wyoming / Mississippi	1.5m x 1.8m (5' x 6')	LL LB56WU

Portable Backgrounds

Dyed Backgrounds Swatches



Washington



Dakota



Florida



Maine



Wyoming



Arizona

Dyed Knitted Ezycare Backgrounds

The dyed knitted Ezycare curtain backgrounds come in six popular colours and are made from a knitted fabric which can be draped or stretched to instantly remove any creases. Fully machine washable at 40°C (105°F) in a large washing machine, these backgrounds are available in two sizes 3m x 3.5m and 3m x 7m. Each background is supplied in a handy tote bag and features a hem on the 3m edge to insert a pole for support. A set of four clips are included to secure the background when stretched between the stands of a support system. Two sand bags are also included to secure the floor section of the background.

Features and Benefits

- ▶ Available in 3m x 3.5m (10' x 12') and 3m x 7m (10' x 24')
- ▶ Six colours
- ▶ Creases can be removed by stretching the fabric
- ▶ Support systems available (page 64-65)



Dyed Knitted Ezycare Background – stretched



Dyed Knitted Ezycare Background – draped



Specifications

Dyed Knitted Ezycare Backgrounds	3m x 3.5m (10' x 12')	3m x 7m (10' x 24')
Washington	LL LB7540	LL LB7640
Dakota	LL LB7541	LL LB7641
Florida	LL LB7546	LL LB7646
Maine	LL LB7548	LL LB7648
Wyoming	LL LB7550	LL LB7650
Arizona	LL LB7554	LL LB7654

Portable Backgrounds

Panoramic Background Swatches



Chromakey Green



Black



Granite



Limestone

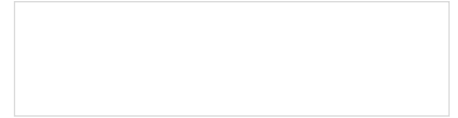

White

Panoramic Background

The Panoramic background is one of our widest, crease free textile surfaces. It features a collapsible three panel aluminium framework, creating a useful self-supporting wraparound structure. The fabric cover clips to the framework and is available in three solid colours – Black, Chromakey Green and White and two textured surfaces – Granite and Limestone.

The Panoramic background is ideal for shooting larger groups on location, perfect for weddings, prom nights and event photography. The background folds down neatly into its own case and fits easily into a car.

Features and Benefits

- ▶ Up to 4m (13') wide and 2.3m (7'5") high
- ▶ Self-supporting
- ▶ Weighs only 9kg (19.8lb)
- ▶ Packs into a 100cm x 30cm x 35cm (39" x 12" x 13.5") bag



Portable Backgrounds



Specifications		
Panoramic Background	Size	Code
Panoramic Background - Granite	4m (13')	LL LB7901
Panoramic Background - Limestone	4m (13')	LL LB7902
Panoramic Background - Black	4m (13')	LL LB7621
Panoramic Background - Green	4m (13')	LL LB7622
Panoramic Background - White	4m (13')	LL LB7623
Panoramic Background Cover - Granite	4m (13')	LL LB7903
Panoramic Background Cover - Limestone	4m (13')	LL LB7904
Panoramic Background Cover - Black	4m (13')	LL LB7625
Panoramic Background Cover - Green	4m (13')	LL LB7626
Panoramic Background Cover - White	4m (13')	LL LB7627





“ The HiLite is probably the best investment you will ever make as a photographer who uses flash. Why? There is not any other flash based product on the market that has so many uses to create so many styles and in any location. From a background to a window light, the HiLite allows you to shoot big light anywhere, producing a window light quality or a portable pure white background. ”

Mark Cleghorn, Photographer & Director of The Photographer Academy.



Getting creative with the HiLite by putting the model inside, there's so much you can do with a HiLite.



The HiLite is not only a background. It can be used as a huge full length softbox.



The HiLite is so simple to set up. Just attach a short rod to each corner and it's ready to shoot.

Portable Backgrounds

HiLite Backgrounds **PATENTED**

The HiLite backgrounds range allows the photographer to work in a way that was extremely difficult to achieve in the past, 'high key' photography on location and in restrictive spaces. By rear lighting the white background itself there is no longer a need to use a background light behind the subject. Furthermore, because the background is actually illuminated it means the subject can stand virtually right in front of it without casting a shadow. The HiLite backgrounds also works as a large rear softbox and illuminates the subject as well, meaning you can use just one other flash head to light the subject from the front. What's more, the whole thing is collapsible.



Features and Benefits

- ▶ Available in four sizes 1m x 1.4m (3'6" x 4'6"), 1.5m x 2.15m (5' x 7'), 1.8m x 2.15m (6' x 7') and 2.15m x 2.5m (7' x 8')
- ▶ Can be rotated and used on its short or long edge
- ▶ An optional 'wipe clean' vinyl train is also available that attaches to either edge for full length work
- ▶ Can be suspended on our LL LA1108 background support system
- ▶ Can even be used as a very large softbox
- ▶ Free standing



Specifications

HiLite Background	Code
HiLite 1m x 1.4m (3'6" x 4'6")	LL LB8990
HiLite 1.5m x 2.15m (5' x 7')	LL LB8857
HiLite 1.8m x 2.15m (6' x 7')	LL LB8867
HiLite 2.15m x 2.5m (7' x 8')	LL LB8878
Cleanable Vinyl Train	Code
For the 1.5m x 2.15m (5' x 7') HiLite	LL LB8858
For the 1.8m x 2.15m (6' x 7') HiLite	LL LB8868
For the 2.15m x 2.5m (7' x 8') HiLite	LL LB8879

Portable Backgrounds



LL LB8878



LL LB8990



HiLite Bottletop Swatches



Super Black



Grey



ChromaKey Green

HiLite Bottletops

The bottletop background covers with a train now make the HiLite product range even more versatile. These backgrounds stretch over the HiLite and allow the photographer to quickly switch from a high key to a low or mid key environment. When using the covers the HiLite should not be illuminated from the rear.



Features and Benefits

- ▶ Switch from high key to mid or low key in an instant
- ▶ Designed to fit the 1.8m x 2.15m (6' x 7') HiLite
- ▶ Available in three colours

Specifications

HiLite Bottletops	Code
Super Black 1.8m x 2.15m (6' x 7')	LL LB8803
Grey 1.8m x 2.15m (6' x 7')	LL LB8870
ChromaKey Green 1.8m x 2.15m (6' x 7')	LL LB8881

HiLite Accessories

Originally launched as an illuminated high key background the HiLite can also be used as an incredibly large full-length softbox, offering beautiful soft light. To offer ultimate control and creativity as a softbox we offer three accessories:

- HiLite Window Voile - turns the HiLite into a huge head to toe window light, allowing photographers to create the illusion that the subject is looking out through a large window or doorway.
- HiLite Shaper – a 86cm wide opaque black panel that masks the light allowing the photographer to create a single strip of light or split the light into two strips. Each offers a different lighting effect allowing the photographer to be as creative as they wish.
- HiLite Shapers and Masks - The shapers work as above however in this set there are three of them which allows the photographer maximum control. This set also includes three masks, which attaches to the top and the sides of the HiLite to ensure no light is spilled giving the photographer complete control.

All accessories are compatible with the 1.8m x 2.15m (6' x 7') HiLite only.

Features and Benefits

- ▶ Designed for using the HiLite as a softbox
- ▶ Compatible with the 1.8m x 2.15m (6' x 7') version only
- ▶ 3 different accessories
- ▶ Unlimited creative potential

Specifications

HiLite Accessories	Code
HiLite Window Voile	LL LB8969
HiLite Shaper	LL LB8968
HiLite Shapers and Masks	LL LB8967



LL LB8969



LL LB8968



LL LB8967

Chromakey Backgrounds

Chromakey Collapsible Swatches



Chromakey Green



Chromakey Blue



Black



White

Chromakey Collapsible Reversibles

Chromakey has been used in film and cinema production as a tool to mix two or more images together in all aspects of the art. It is increasingly used in digital photography to cut and paste a subject onto a background.



Features and Benefits

- ▶ Reversible
- ▶ Chromakey rim tape as standard
- ▶ Crease resistant fabric
- ▶ Fast to set up and dismantle
- ▶ For inside and outside use
- ▶ Collapses to a third of its original size



Specifications

Chromakey Collapsible Background	Size	Code
Chromakey Blue/ Green Reversible	1.5m x 1.8m (5' x 6')	LL LC5687
	1.8m x 2.1m (6' x 7')	LL LC5987
Black/White Reversible	1.5m x 1.8m (5' x 6')	LL LC5621
	1.8m x 2.15m (6' x 7')	LL LB5921
Chromakey Green	1.8m x 2.75m (6' x 9')	LL LB6921
	1.8m x 2.1m (6' x 7')	LL LC5981
	1.8m x 2.75m (6' x 9')	LL LC6981

Chromakey Backgrounds

Chromakey Curtain Swatches



Chromakey Green



Chromakey Blue

Chromakey Curtain

The Lastolite By Manfrotto Chromakey Curtains are available in two sizes, 3m x 3.5m (10' x 12") and 3m x 7m (10' x 24"). Choose from Green or reversible Blue / Green versions. For most effective use, mount with Lastolite's background support system (see page 64–65).



Features and Benefits

- ▶ Available in green and reversible blue/green
- ▶ Machine washable 40 degrees celcius
- ▶ Stretches to remove creases
- ▶ Available in two sizes

Specifications

Chromakey Curtains	3m x 3.5m (10' x 12')	3m x 7m (10' x 24')
Green	LL LC5781	
Reversible Blue/Green	LL LC5787	
Green		LL LC5881
Reversible Blue/Green		LL LC5887



Seamless Backgrounds

Paper Roll Backgrounds



Features and Benefits

- ▶ Support systems available
- ▶ Available in 3 sizes
- ▶ Comprehensive range of colours
- ▶ Totally crease free
- ▶ Disposable if marked
- ▶ Cut your own custom lengths

Specifications

Paper Roll Backgrounds size: 2.72m x 11m (107"x36')	Code
Super White	LL LP9001
Heaven	LL LP9002
Corn	LL LP9004
Navy	LL LP9005
Wine	LL LP9006
Red	LL LP9008
Arctic Grey	LL LP9012
Conker	LL LP9016
Black	LL LP9020
Marigold	LL LP9024
Sandstone	LL LP9025
Flint	LL LP9026
Shadow Grey	LL LP9027
Amethyst	LL LP9029
Ocean	LL LP9030
Kingfisher	LL LP9031
Grass Green	LL LP9035
Gala Pink	LL LP9037
Primrose	LL LP9038
Leaf Green	LL LP9046
Aztec	LL LP9047
White	LL LP9050
Ivory	LL LP9051
Graphite	LL LP9054
Royal	LL LP9058
Pewter	LL LP9060
Purple	LL LP9062
Regal Blue	LL LP9065
Yellow	LL LP9071
Chromakey Green	LL LP9073
Size: 1.35m x 11m (53" x 36')	Code
Super White	LL LP9101
Black	LL LP9120
Shadow Grey	LL LP9127
Size: 3.55m x 30m (140" x 98')	Code
Super White	LL LP9201
Black	LL LP9220



Seamless Backgrounds

Superwhite Vinyl Backgrounds

Lastolite's 'wipe clean' Superwhite vinyl background can literally be used over and over again. Simply wipe away any dirt or footprints at the end of your shoot, then roll it back up ready for next time! It couldn't be easier. Supplied on a roll the same width as our standard paper backgrounds (2.75m) the Superwhite vinyl can easily be suspended using our LL LB1128 background support system, while the 3.5m can be suspended using the 4m Solo Background Support (LL LB1142).

Note: Not compatible with the Manfrotto Expan Drive System



Features and Benefits

- ▶ Wipe clean
- ▶ Long lasting
- ▶ Ideal for 'high key' photography'
- ▶ 2.75m x 6m (9' x 20') and 3.5m x 6m (11'5" x 20')

Specifications

Superwhite Vinyl Background	Code
Superwhite Vinyl Background 2.75m x 6m	LL LB7761
Superwhite Vinyl Background 3.5m x 6m	LL LB7763



Black Vinyl Background

The vinyl background 2.75 x 6m (9' x 20') is also available in Black.

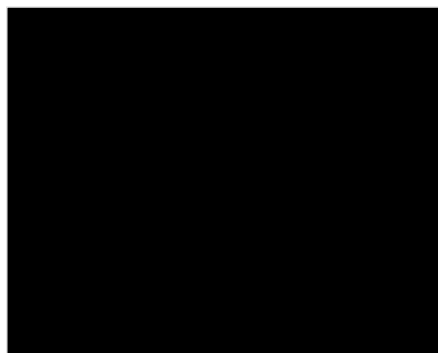

LL LB7765

Features and Benefits

- ▶ Available in Black
- ▶ 2.75m x 6m (9' x 20')
- ▶ Wipe clean
- ▶ Long lasting

Specifications

Coloured Vinyl backgrounds	Code
Black Vinyl Background	LL LB7765

Background Supports

Magnetic Background Support

PATENT PENDING

The Lastolite By Manfrotto Magnetic Background Support makes attaching and removing backgrounds simple. The steel band located within the rim of The Lastolite by Manfrotto backgrounds attaches directly to the two magnetic housings on the crossbar. The support can be raised to its desired position and the background simply lifted into position. The Magnetic Background Support will fit to most lighting stands with a 5/8" spigot. A kit is also available which includes a LL LS1159 lighting stand and carry case.

Features and Benefits

- ▶ Magnetic connectors
- ▶ Universal fitting
- ▶ Available as a kit*
- ▶ Holds up to 5kg (11lb)

Specifications

Magnetic Background Support	Code
Magnetic Background Support	LL LB1120
Magnetic Background Support Kit*	LL LB1121

*Kit includes Magnetic Background support, LL LS1159 light stand and carry case



Magnetic Background Support LL LB1120



Magnetic connectors



Fit to Out of Focus Background



Fits to most lighting stands



Magnetic Background Support Kit LL LB1121

Solo Background Support

The Solo background support features a unique pivoting cross bar which makes raising the background on the supports a much easier and safer operation. Rather than step by step adjustments at each end of the support system the new pivoting connectors allow for much greater steps without making the whole structure unstable and unmanageable. The support is available as a 3m wide or 4m wide solution. The 4m version can also be extended to 6m to accommodate wider textile backgrounds and features our heavy duty stands which allow the use of our wide width vinyl (page 59). Each kit comes in a handy carry case which fits easily into a car.

Features and Benefits

- ▶ Single user operation
- ▶ Unique pivoting cross bar
- ▶ 3m, 4m and 6m widths, up to 2.8m high

Specifications

Solo Background Support	Code
Solo Background Support 3m (10')	LL LB1105
Solo Background Support 4m (13') Heavy Duty	LL LB1142
Solo Background Support Extension* 2m (6.5')	LL LB1143

*For 4m Background Support only



Solo Support Brackets

Background Supports

Background Supports

There are a number of background supports systems to accommodate curtain, collapsible and roll up backgrounds.



LL LA1108

Specifications

Background supports	Code
Support for 3m (10') wide curtain and roll up backgrounds (metal collars)	LL LA1108
Heavy duty support for paper and vinyl roll up backgrounds (metal collars)	LL LB1128
Telescopic crossbar	LL LB1119



LL LA1108



LL LB1119



LL LB1128

Cubelite®

The Cubelite® allows the photographer to control the lighting of products, minimizing shadows and isolating the subject from the background.

It's never been easier to take quick and crisp product shots on location or in the studio. The Cubelite® has been enhanced in a number of ways so as to improve its utility:

- Background clips mounted in the roof for additional height.
- Open base for even floor surface, easier to fold, and enables positioning of cube over immovable items e.g. plants.
- Front opens to edge of Cubelite® for wider viewing angles.

The Cubelite® offers a true location studio which instantly pops open ready for work.



Specifications

Cubelite®	Size	Code
Cubelite	45cm (18")	LL LR1886
Cubelite	58cm (2')	LL LR2486
Cubelite	90cm (3')	LL LR3686
Cubelite with removable back	90cm (3')	LL LR3687
Cubelite	120cm (4')	LL LR4886
Cubelite	1.5m x 1.5m x 2.1m (5' x 5' x 7')	LL LR5287
Cubelite	2m x 2m x 2.1m (6'6" x 6'6" x 7')	LL LR6687

Features and Benefits

- ▶ Ideal for product shots
- ▶ Shadowless lighting
- ▶ Perfect for digital or film use
- ▶ Isolates subject
- ▶ Collapses to a third of its original size



Product Photography

Cubelite® Kit

The Cubelite® Kit contains everything you need to take professional photographs with controlled shadows - just add your digital camera! The Cubelite® kit now includes a lighting guide by Michael Freeman.

Features and Benefits

- ▶ Kit has all you need to take professional product photographs
- ▶ Just add your digital camera!
- ▶ Fluorescent lighting



Fluorescent Light

Specifications

Cubelite® Kit Fluorescent	Cubelite®	Light stand	Fluorescent Light	85w Bulb	Silver / White Reflector	White Vinyl Background	lighting guide	Code
90cm (3') Kit	1	1	1	1	1	1	1	LL LR3662

Studio Cubelite® **PATENTED**

The Studio Cubelite® is the ultimate solution for product photography and takes our highly successful Cubelite® concept even further. It allows for control of the light from below and all other directions allowing the photographer to give products that floating look with no shadows if desired. The tensioned diffuser fabric means the reflections on even the most reflective surface are kept to an absolute minimum, whilst the generous front opening can be closed to mask reflections from the camera/operator as well. The patented design also allows you to control the light from underneath by pointing the source up or down into the base unit giving different light distribution effects and creating graduated backgrounds if required.



Features and Benefits

- ▶ 360 degree lighting
- ▶ Full shadow control
- ▶ Reflection control
- ▶ Collapses flat in minutes with simple tensioning rods
- ▶ Features a unique base diffusion system
- ▶ Includes a diffused film to create the translucent background
- ▶ Includes an acrylic top surface for heavier items up to 8kg (17.6lb)



Specifications

Studio Cubelite®	Size	Code
Studio Cubelite®	70cm x 70cm x 155cm (28" x 28" x 61")	LL LR8824
Studio Cubelite®	100cm x 100cm x 185cm (39" x 39" x 73")	LL LR8836

Product Photography

LiteTable PATENTED

The Lastolite By Manfrotto still life table "LiteTable" will revolutionize your product photography with its ease of use and light control. It can be assembled in minutes (without the use of any screws, bolts or allen keys!) and folds flat into a handy carry case when not in use, making it ideal for occasional use and location work. The unique patented design allows the photographer to control the light distribution underneath the table by positioning the light in different ways, creating graduated backgrounds or a completely even tone. With gels the creative possibilities are endless. Many of these techniques have previously been difficult with conventional light tables as they have open sides underneath.



With illuminated LiteTable base



Without illuminated LiteTable base

Features and Benefits

- ▶ Available in two sizes
- ▶ Includes an acrylic top surface for heavier items up to 8kg (17.6lb)
- ▶ Includes a translucent background film to create an infinity curve

Specifications

LiteTable	Size	Code
LiteTable	70cm x 70cm x 150cm (28" x 28" x 60")	LL LR7824
LiteTable	1m x 1m x 1.8m (39" x 39" x 72")	LL LR7836



ePhotomaker

The ePhotomaker has been designed for eBay and other online auction users looking to improve their images. Having well-lit photos with accurate colours can make the difference between selling or not selling a product. The ePhotomaker features a diffusing fabric on one side to soften the light and a reflector to fill in the shadows on the other side. All you need to provide is an ordinary domestic desk lamp. The ePhotomaker kit includes an EzyBalance grey card to control colours and exposure resulting in photographs with crisp white backgrounds. The kit also includes a tabletop tripod.



Features and Benefits

- ▶ Ideal for selling products on the web
- ▶ Supplied with a blue gel to simulate daylight lighting conditions
- ▶ Collapsible - easy to store
- ▶ Built in reflector on one side, diffuser on the other side
- ▶ Kit contains ePhotomaker, EzyBalance, Blue daylight gel, clips and Tripod

Specifications

ePhotomaker	Code
ePhotomaker Small Kit	LL LR2484
ePhotomaker Large Kit	LL LR3684

ePhotomaker kit contains:

- ePhotomaker
- EzyBalance 'Point and Shoot' (grey surface only)
- Tabletop tripod
- Blue daylight gel with clips

Brackets and Handles



Camera Bracket LL LS2408 horizontal position



Camera Bracket LL LS2408 vertical position



Non Rotating Extending Handle LL LS2453



LL LS2452



LL LS2400



Tilthead with Spigot LL LA2401



Tilthead Shoe Lock LL LA2422

Specifications	
Brackets and Handles	Code
Camera Bracket	LL LA2408
Extending Handle 24cm – 48cm (9.5" – 19")	LL LS2400
Non Rotating Extending Handle 70cm – 176cm (27.5" – 69")*	LL LS2452
Non rotating Extending Handle 74cm – 232cm (29" – 91")*	LL LS2453
Tiltheads	Code
Tilthead Shoe Lock	LL LA2422
Tilthead with spigot	LL LA2401

*Includes Waist Holder

Lighting Stands

Stands

There are a number of different lighting and support stands available.



4 Section Heavy Duty LL LS1160 (left)
4 Section Standard LL LS1158 (right)



4 Section Air Cushioned LL LS1159



Sand Bag LL LB1592



Metal Collar



Specifications	
Stands	Code
4 section standard lighting stand with plastic collars - Collapsible height: 84cm (33") Minimum height: 99cm (39") Maximum height: 310cm (122") Spread: 120cm (47") Loading capacity: 2.5kg (5.5lb) Net Weight: 1.25kg (2.8lb) Maximum loading capacity, when each section is shortened by 2.54cm (1"): 4kg (8.8lb)	LL LS1158
4 section air cushioned lighting stand with metal collars - Collapsible height: 84cm (33") Minimum height: 99cm (39") Maximum height: 298cm (117") Spread: 120cm (47") Loading capacity: 3kg (6.6lb) Net Weight: 1.33kg (2.9lb) Maximum loading capacity, when each section is shortened by 2.54cm (1"): 5kg (11lb)	LL LS1159
4 section heavy duty air cushioned lighting stand with metal collars extends from 104cm - 352cm high (41" - 138.5")	LL LS1160
Sand Bag	LL LB1592

Posing Tubs



Features and Benefits

- ▶ Variety of sizes
- ▶ Nestable 'Russian Doll' style for easy storage
- ▶ Hard wearing nylon covers with padded seats
- ▶ Includes a carry case with shoulder strap
- ▶ White covers are a simple slide on 'sock' design

Specifications

Posing Tubs	Code
Posing Tubs	LL LA8014
White Posing Tub Covers	LL LA8015



Baby Poser

The baby poser is a range of bead filled cushions designed to support a baby securely during the shoot. The cushions can be configured in different ways to pose babies of all ages comfortably on their back or front, kneeling or standing. When the cushions are positioned how you want them, fabric can be placed over the cushions to create the background colour of your choice. Each cushion is covered with a waterproof fabric in case of any little accidents!



Features and Benefits

- ▶ Multi position
- ▶ Waterproof covering
- ▶ Supports babies of all ages

Specifications

Baby Poser	Code
Baby Poser	LL LA8017



Art. No	Description	Page	Art. No	Description	Page
Art. No.	Description	Page	LL LB7623	Panoramic Background 4m (13') White	54
LL LA1100	Universal Bracket for 50cm - 120cm Collapsible Reflectors	12	LL LB7625	Panoramic Background Cover 4m (13') Black	54
LL LA1107	Panelite Bracket for 95cm - 180cm Reflectors	12	LL LB7626	Panoramic Background Cover 4m (13') Chromakey Green	54
LL LA1108	Support for 3m (10') Curtain & Roll Up Backgrounds (Metal Collars)	66	LL LB7627	Panoramic Background Cover 4m (13') White	54
LL LA2401	Tilthead with Spigot	71	LL LB7640	Knitted Ezycare 3m x 7m (10' x 24') Washington	53
LL LA2408	Camera Bracket	71	LL LB7641	Knitted Ezycare 3m x 7m (10' x 24') Dakota	53
LL LA2422	Tilthead Shoe Lock	71	LL LB7646	Knitted Ezycare 3m x 7m (10' x 24') Florida	53
LL LA2423	TriFlash Shoe Lock Bracket with 3 Locking Shoe Mounts	35	LL LB7648	Knitted Ezycare 3m x 7m (10' x 24') Maine	53
LL LA2430	TriGrip Bracket	9	LL LB7650	Knitted Ezycare 3m x 7m (10' x 24') Wyoming	53
LL LA8014	Posing Tubes	73	LL LB7654	Knitted Ezycare 3m x 7m (10' x 24') Arizona	53
LL LA8015	White Posing Tub Covers for LL LA8014	73	LL LB7761	Vinyl Background 2.75m x 6m (9' x 20') Superwhite	63
LL LA8017	Baby Poser	73	LL LB7763	Vinyl Background 3.5m x 6m (11'5" x 20') Superwhite	63
LL LA8446	Skylite Rapid Griphead	15	LL LB7765	Vinyl Background 2.75m x 6m (9' x 20') Black	63
LL LA8449	Skylite Rapid Crossbar Handle	15	LL LB7901	Panoramic Background 4m Granite	54
LL LB1105	Solo Background Support 3m (10')	65	LL LB7902	Panoramic Background 4m Limestone	54
LL LB1119	Telescopic Crossbar	66	LL LB7903	Panoramic Background Cover 4m Granite	54
LL LB1120	Magnetic Background Support	64	LL LB7904	Panoramic Background Cover 4m Limestone	54
LL LB1121	Magnetic Background Support Kit with Stand	64	LL LB8803	HiLite Bottletop With Train 1.8m x 2.15m (6' x 7') Super Black	58
LL LB1128	Heavy Duty Support for Roll Up Backgrounds (Metal Collars)	66	LL LB8857	HiLite Background 1.5m x 2.15m (5' x 7')	57
LL LB1142	Solo Background Support 4m (13') Heavy Duty	65	LL LB8858	Cleanable Vinyl Train for the 1.5m x 2.15m (5' x 7') HiLite	57
LL LB1143	Solo Background Support Extension 2m (6.5')	65	LL LB8867	HiLite Background 1.8m x 2.15m (6' x 7')	57
LL LB1592	Sand Bag	72	LL LB8868	Cleanable Vinyl Train for the 1.8m x 2.15m (6' x 7') HiLite	57
LL LB56FM	Dyed Collapsible 1.5m x 1.8m (5' x 6') Florida / Maine	52	LL LB8870	HiLite Bottletop With Train 1.8m x 2.15m (6' x 7') Grey	58
LL LB56GB	Plain Collapsible 1.5m x 1.8m (5' x 6') Black / Mid Grey	47	LL LB8878	HiLite Background 2.5m x 2.15m (7' x 8')	57
LL LB56GW	Plain Collapsible 1.5m x 1.8m (5' x 6') White / Mid Grey	47	LL LB8879	Cleanable Vinyl Train for the 2.15m x 2.5m (7' x 8') HiLite	57
LL LB56WD	Dyed Collapsible 1.5m x 1.8m (5' x 6') Washington / Dakota	52	LL LB8881	HiLite Bottletop With Train 1.8m x 2.15m (6' x 7') Chromakey Green	58
LL LB56WU	Dyed Collapsible 1.5m x 1.8m (5' x 6') Wyoming / Mississippi	52	LL LB8967	HiLite 1.8m x 2.15m (6' X 7') Shaper & Masks	59
LL LB5711	Urban Collapsible 1.5m x 2.1m (5' x 7') Red Brick / Grey Stone	48	LL LB8968	HiLite 1.8m x 2.15m (6' X 7') Shaper	59
LL LB5712	Urban Collapsible 1.5m x 2.1m (5' x 7') Corrugated / Metal	48	LL LB8969	HiLite 1.8m x 2.15m (6' X 7') Window Voile	59
LL LB5713	Urban Collapsible 1.5m x 2.1m (5' x 7') Rusty Metal / Plaster Wall	48	LL LB8990	HiLite Background 1m x 1.4m (3'6" x 4'6")	57
LL LB5714	Urban Collapsible 1.5m x 2.1m (5' x 7') Distressed Paper / Graffiti	48	LL LC5621	Plain Collapsible Reversible 1.5m x 1.8m (5' x 6') Black / White	47,60
LL LB5715	Urban Collapsible 1.5m x 2.1m (5' x 7') Derelict Wall / Wooden Fence	48	LL LC5687	Collapsible Reversible 1.5m x 1.8m (5' x 6') Chromakey Blue / Green	60
LL LB5717	Urban Collapsible 1.5m x 2.1m (5' x 7') Shutter / Distressed Door	48	LL LC5781	Chromakey Curtain 3m x 3.5m (10' x 12') Green	61
LL LB5718	Urban Collapsible 1.5m x 2.1m (5' x 7') Tarnished Metal / Container	48	LL LC5787	Chromakey Curtain Reversible 3m x 3.5m (10' x 12') Blue / Green	61
LL LB5730	Out of Focus Collapsible 1.2m x 1.5m (4' x 5') Summer Foliage / City Lights	51	LL LC5881	Chromakey Curtain 3m x 7m (10' x 24') Green	61
LL LB5731	Out of Focus Collapsible 1.2m x 1.5m (4' x 5') Autumn Foliage / Seascape	51	LL LC5887	Chromakey Curtain Reversible 3m x 7m (10' x 24') Blue / Green	61
LL LB5740	Perspective Collapsible 1.5m x 2.1m (5' x 7') Stone Steps / Winter Trees	50	LL LC5981	Collapsible 1.8m x 2.1m (6' x 7') Chromakey Green	60
LL LB5741	Perspective Collapsible 1.5m x 2.1m (5' x 7') Stone Arch / Grecian Steps	50	LL LC5987	Collapsible Reversible 1.8m x 2.1m (6' x 7') Chromakey Blue / Green	60
LL LB5742	Perspective Collapsible 1.5m x 2.1m (5' x 7') Evening Street Ivy Archway	50	LL LC6981	Collapsible 1.8m x 2.75m (6' x 9') Chromakey Green	60
LL LB5745	Urban Collapsible 1.5m x 2.1m (5' x 7') Smoke/Concrete	48	LL LL3603	RayD8 C3200 Single Head Kit/Power Cable & Reflector Dish	17
LL LB5921	Plain Collapsible Reversible 1.8 x 2.15m (6' x 7') Black / White	47,60	LL LP9001	Paper 2.72m x 11m (108" x 36") Super White	62
LL LB6488	MegaLite Softbox/Reflector 1.2 x 1.8m (4' x 6')	46	LL LP9002	Paper 2.72m x 11m (108" x 36") Heaven	62
LL LB6489	MegaLite Adjustable Stand with Wheels	46	LL LP9004	Paper 2.72m x 11m (108" x 36") Corn	62
LL LB6701	Plain Collapsible 1.8m x 2.15m (6' x 7') Black / White With Train	47	LL LP9005	Paper 2.72m x 11m (108" x 36") Navy	62
LL LB6751	Plain Collapsible 1.8m x 2.15m (6' x 7') Blue / Pink	47	LL LP9006	Paper 2.72m x 11m (108" x 36") Wine	62
LL LB6752	Plain Collapsible 1.8m x 2.15m (6' x 7') Red / Purple	47	LL LP9008	Paper 2.72m x 11m (108" x 36") Red	62
LL LB67GB	Plain Collapsible 1.8m x 2.15m (6' x 7') Black / Mid Grey	47	LL LP9012	Paper 2.72m x 11m (108" x 36") Arctic Grey	62
LL LB67GW	Plain Collapsible 1.8m x 2.15m (6' x 7') White / Mid Grey	47	LL LP9016	Paper 2.72m x 11m (108" x 36") Conker	62
LL LB6921	Plain Collapsible Reversible 1.8m x 2.75m (6' x 9') (6' x 9') Black / White	47,60	LL LP9020	Paper 2.72m x 11m (108" x 36") Black	62
LL LB7540	Knitted Ezycare 3m x 3.5m (10' x 12') Washington	53	LL LP9024	Paper 2.72m x 11m (108" x 36") Marigold	62
LL LB7541	Knitted Ezycare 3m x 3.5m (10' x 12') Dakota	53	LL LP9025	Paper 2.72m x 11m (108" x 36") Sandstone	62
LL LB7546	Knitted Ezycare 3m x 3.5m (10' x 12') Florida	53	LL LP9026	Paper 2.72m x 11m (108" x 36") Paper Flint	62
LL LB7548	Knitted Ezycare 3m x 3.5m (10' x 12') Maine	53	LL LP9027	Paper 2.72m x 11m (108" x 36") Shadow Grey	62
LL LB7550	Knitted Ezycare 3m x 3.5m (10' x 12') Wyoming	53	LL LP9029	Paper 2.72m x 11m (108" x 36") Amethyst	62
LL LB7554	Knitted Ezycare 3m x 3.5m (10' x 12') Arizona	53	LL LP9030	Paper 2.72m x 11m (108" x 36") Ocean	62
LL LB7621	Panoramic Background 4m (13') Black	54	LL LP9031	Paper 2.72m x 11m (108" x 36") Kingfisher	62
LL LB7622	Panoramic Background 4m (13') Chromakey Green	54	LL LP9035	Paper 2.72m x 11m (108" x 36") Grass Green	62
			LL LP9037	Paper 2.72m x 11m (108" x 36") Gala Pink	62
			LL LP9038	Paper 2.72m x 11m (108" x 36") Primrose	62
			LL LP9046	Paper 2.72m x 11m (108" x 36") Leaf Green	62

Art. No	Description	Page	Art. No	Description	Page
LL LP9047	Paper 2.72m x 11m (108" x 36') Aztec	62	LL LR3607	TriGrip Diffuser 75cm (30") 2 Stop	7
LL LP9050	Paper 2.72m x 11m (108" x 36') White	62	LL LR3628	TriGrip Reflector 75cm (30") Sunlite / Soft Silver	7
LL LP9051	Paper 2.72m x 11m (108" x 36') Ivory	62	LL LR3631	TriGrip Reflector 75cm (30") Silver / White	7
LL LP9054	Paper 2.72m x 11m (108" x 36') Graphite	62	LL LR3636	TriGrip Reflector 75cm (30") Sunfire / Silver	7
LL LP9058	Paper 2.72m x 11m (108" x 36') Royal	62	LL LR3641	TriGrip Reflector 75cm (30") Gold / White	7
LL LP9060	Paper 2.72m x 11m (108" x 36') Pewter	62	LL LR3651	TriGrip Diffuser 75cm (30") 1 Stop	7
LL LP9062	Paper 2.72m x 11m (108" x 36') Purple	62	LL LR3652	TriGrip Diffuser 75cm (30") Soft Silver	10
LL LP9065	Paper 2.72m x 11m (108" x 36') Regal Blue	62	LL LR3662	Cubelite Kit 90cm (3') Fluorescent 85w 220v	68
LL LP9071	Paper 2.72m x 11m (108" x 36') Yellow	62	LL LR3684	E Photomaker Large Kit	70
LL LP9073	Paper 2.72m x 11m (108" x 36') Chromakey Green	62	LL LR3686	Cubelite 90cm (3')	67
LL LP9101	Paper 1.35m x 11m (53" x 36') Super White	62	LL LR3687	Cubelite With Removable Back 90cm (3')	67
LL LP9120	Paper 1.35m x 11m (53" x 36') Black	62	LL LR3696	TriFlip 8:1 Kit 75cm (30") 2 Stop Diffuser + 2 TriFlip Covers	8
LL LP9127	Paper 1.35m x 11m (53" x 36') Shallow Grey	62	LL LR3699	TriFlip 8:1 Deluxe Kit 75cm (30")	9
LL LP9201	Paper 3.55m x 30m (140" x 98') Super White	62	LL LR3707	TriGrip Diffuser Large 1.2m (48") 2 Stop	7
LL LP9220	Paper 3.55m x 30m (140" x 98') Black	62	LL LR3728	TriGrip Reflector Large 1.2m (48") Sunlite / Soft Silver	7
LL LR1206	Collapsible Reflector 30cm (12") Sunfire / White	11	LL LR3731	TriGrip Reflector Large 1.2m (48") Silver / White	7
LL LR1228	Collapsible Reflector 30cm (12") Sunlite / Soft Silver	11	LL LR3736	TriGrip Reflector Large 1.2m (48") Sunfire / Silver	7
LL LR1231	Collapsible Reflector 30cm (12") Silver / White	11	LL LR3741	TriGrip Reflector Large 1.2m (48") Gold / White	7
LL LR1234	Collapsible Reflector 30cm (12") Silver / Gold	11	LL LR3751	TriGrip Diffuser Large 1.2m (48") 1 Stop	7
LL LR1236	Collapsible Reflector 30cm (12") Sunfire / Silver	11	LL LR3752	TriGrip Diffuser Large 1.2m (48") Soft Silver	10
LL LR1241	Collapsible Reflector 30cm (12") Gold / White	11	LL LR3806	Collapsible Reflector 95cm (38") Sunfire / White	11
LL LR1250	EzyBalance 30cm (12") 18% Grey	16	LL LR3807	Collapsible Diffuser 95cm (38") 2 Stop	11
LL LR1252	EzyBalance For Scuba Divers 30cm (12") 18% Grey	16	LL LR3828	Collapsible Reflector 95cm (38") Sunlite / Soft Silver	11
LL LR1558	XpoBalance 38cm (15")	16	LL LR3831	Collapsible Reflector 95cm (38") Silver / White	11
LL LR1886	Cubelite 45cm (18")	67	LL LR3834	Collapsible Reflector 95cm (38") Silver / Gold	11
LL LR2006	Collapsible Reflector 50cm (20") Sunfire / White	11	LL LR3836	Collapsible Reflector 95cm (38") Sunfire / Silver	11
LL LR2007	Collapsible Diffuser 50cm (20") 2 Stop	11	LL LR3841	Collapsible Reflector 95cm (38") Gold / White	11
LL LR2028	Collapsible Reflector 50cm (20") Sunlite / Soft Silver	11	LL LR3896	Bottletop 5:1 95cm (38") Diffuser + Gold/White & Sunfire / Silver	12
LL LR2031	Collapsible Reflector 50cm (20") Silver / White	11	LL LR4806	Collapsible Reflector 1.2m (48") Sunfire / White	11
LL LR2034	Collapsible Reflector 50cm (20") Silver / Gold	11	LL LR4807	Collapsible Diffuser 1.2m (48") 2 Stop	11
LL LR2036	Collapsible Reflector 50cm (20") Sunfire / Silver	11	LL LR4828	Collapsible Reflector 1.2m (48") Sunlite / Soft Silver	11
LL LR2041	Collapsible Reflector 50cm (20") Gold / White	11	LL LR4831	Collapsible Reflector 1.2m (48") Silver / White	11
LL LR2050	EzyBalance 50cm (20") 18% Grey	16	LL LR4834	Collapsible Reflector 1.2m (48") Silver / Gold	11
LL LR2096	Bottletop 5:1 50cm (20") Diffuser + Gold/White & Sunfire / Silver	12	LL LR4836	Collapsible Reflector 1.2m (48") Sunfire / Silver	11
LL LR2457JM	Joe McNally Rotating Locking TriFlash Tilthead	39	LL LR4841	Collapsible Reflector 1.2m (48") Gold / White	11
LL LR2462JM	Joe McNally White Ezybox Hotshoe 54 x 54cm (21" x 21")	38	LL LR4886	Cubelite 120cm (4')	67
LL LR2484	E Photomaker Small Kit	70	LL LR4896	Bottletop 5:1 120cm (48") Diffuser + Gold/White & Sunfire / Silver	12
LL LR2486	Cubelite 58cm (2')	67	LL LR5287	Cubelite 1.5m x 1.5m x 2.1m (5' x 6' x 7')	67
LL LR2903	Triflector MKII Set of 3 Silver / White Panels	13	LL LR6687	Cubelite 2m x 2m x 2.1m (6'6" x 6'6" x 7')	67
LL LR2905	Triflector MKII Set of 3 Gold / White Panels	13	LL LR7206	Collapsible Panelite Reflector 1.2 x 188m (4' x 6') Sunfire / White	11
LL LR2933	Triflector MKII Frame + Sunfire / Silver Panels	13	LL LR7207	Collapsible Panelite Diffuser 1.2 x 188m (4' x 6') 2 Stop	11
LL LR2933SP	Triflector MKII Frame, Stand & Sunfire / Silver Panels	13	LL LR7228	Collapsible Panelite Reflector 1.8x1.2m Sunlite / Soft Silver	11
LL LR2933SW	Triflector MKII Frame + Silver / White Panels	13	LL LR7231	Collapsible Panelite Reflector 1.2 x 188m (4' x 6') Silver / White	11
LL LR3006	Collapsible Reflector 75cm (30") Sunfire / White	11	LL LR7234	Collapsible Panelite Reflector 1.2 x 188m (4' x 6') Silver / Gold	11
LL LR3007	Collapsible Diffuser 75cm (30") 2 Stop	11	LL LR7236	Collapsible Panelite Reflector 1.2 x 188m (4' x 6') Sunfire / Silver	11
LL LR3028	Collapsible Reflector 75cm (30") Sunlite / Soft Silver	11	LL LR7241	Collapsible Panelite Reflector 1.2 x 188m (4' x 6') Gold / White	11
LL LR3031	Collapsible Reflector 75cm (30") Silver / White	11	LL LR7824	LiteTable 70cm x 70cm x 150cm (28" x 28" x 60")	70
LL LR3034	Collapsible Reflector 75cm (30") Silver / Gold	11	LL LR7836	LiteTable 1m x 1m x 1.8m (39" x 39" x 72")	70
LL LR3036	Collapsible Reflector 75cm (30") Sunfire / Silver	11	LL LR8035	RayD8 C5600 Kit + 2 Stands	17
LL LR3041	Collapsible Reflector 75cm (30") Gold / White	11	LL LR8036	Colour Corrected 85w Fluorescent Bulb	17
LL LR3050	EzyBalance 75cm (30") 18% Grey	16	LL LR8037	Fluorescent Conversion Kit 220v - Extension Tube & Bulb	17
LL LR3096	Bottletop 5:1 75cm (30") Diffuser + Gold/White & Sunfire / Silver "	12	LL LR811	Skylite Rapid Frame Small 1.1m x 1.1m (3'6" x 3'6")	15
LL LR3497JM	Joe McNally UpLite Kit	40	LL LR81101R	Skylite Rapid Cover Small 1.1m x 1.1m (3'6" x 3'6") 0.75 Stop Diffuser	15
LL LR3507	TriGrip Diffuser Mini 45cm (18") 2 Stop	7	LL LR81102R	Skylite Rapid Cover Small 1.1m x 1.1m (3'6" x 3'6") Black Velvet	15
LL LR3528	TriGrip Reflector Mini 45cm (18") Sunlite / Soft Silver	7	LL LR81106R	Skylite Rapid Cover Small 1.1m x 1.1m (3'6" x 3'6") Sunfire / White	15
LL LR3531	TriGrip Reflector Mini 45cm (18") Silver / White	7	LL LR81107R	Skylite Rapid Cover Small 1.1m x 1.1m (3'6" x 3'6") 1.25 Stop Diffuser	15
LL LR3536	TriGrip Reflector Mini 45cm (18") Sunfire / Silver	7	LL LR81121R	Skylite Rapid Cover Small 1.1m x 1.1m (3'6" x 3'6") Black / White	15
LL LR3541	TriGrip Reflector Mini 45cm (18") Gold / White	7	LL LR81131R	Skylite Rapid Cover Small 1.1m x 1.1m (3'6" x 3'6") Silver / White	15
LL LR3551	TriGrip Diffuser Mini 45cm (18") 1 Stop	7	LL LR81143RC	Skylite Rapid Kit Small	15
LL LR3552	TriGrip Diffuser Mini 45cm (18") Soft Silver	10			
LL LR3596	TriFlip 8:1 Mini Kit 45cm (18") 2 Stop Diffuser + 2 TriFlip Covers	8			
LL LR3604	500w P 2/1 Tungsten Bulb 240v E27 UK/EU	17			

Art. No	Description	Page	Art. No	Description	Page
LL LR81146JM	Joe McNally Skylite Rapid with Masks 1.1 x 1.1m (3'6" x 3'6")	39	LL LS2601	Strobo Direct To Flashgun Bracket	31,34
LL LR812	Skylite Rapid Frame Medium 1.1m x 2m (3'6" x 6'6")	15	LL LS2602	Honeycomb Set 3/8" (9mm) and 1/4" (6mm)	31,34
LL LR81201R	Skylite Rapid Cover Medium 1.1m x 2m 0.75 Stop Diffuser	15	LL LS2603	Gel Holder Set (x2)	31,34
LL LR81202R	Skylite Rapid Cover Medium 1.1m x 2m Black Velvet	15	LL LS2604	Gel Set	31,34
LL LR81206R	Skylite Rapid Cover Medium 1.1m x 2m Sunfire / White	15	LL LS2605	Strobo Gel Starter Kit - Direct To Flashgun	31,32
LL LR81207R	Skylite Rapid Cover Medium 1.1m x 2m 1.25 Stop Diffuser	15	LL LS2606	Strobo Honeycomb Starter Kit - Direct To Flashgun	31,32
LL LR81221R	Skylite Rapid Cover Medium 1.1m x 2m Black / White	15	LL LS2611	Strobo Ezybox Hotshoe Plate Adaptor	31,34
LL LR81231R	Skylite Rapid Facric Medium 1.1m x 2m Silver / White	15	LL LS2612	Gobo Set - Architectural	33
LL LR81243RC	Skylite Rapid Kit Medium	15	LL LS2613	Gobo Set - Nature	33
LL LR815	Skylite Rapid Frame Midi 1.5 x 1.5m (5' x 5')	15	LL LS2616	Strobo Kit - Direct To Flashgun	31,32
LL LR81501R	Skylite Rapid Cover Midi 1.5m x 1.5m 0.75 Stop Diffuser	15	LL LS2617	Strobo Kit Ezybox Hotshoe Plate	31,32
LL LR81507R	Skylite Rapid Cover Midi 1.5m x 1.5m 1.25 Stop Diffuser	15	LL LS2619	Strobo Collapsible Snoot	31,33
LL LR81521R	Skylite Rapid Cover Midi 1.5m x 1.5m Black / White	15	LL LS2620	Barn Doors For Strobo	31,34
LL LR81531R	Skylite Rapid Cover Midi 1.5m x 1.5m Silver / White	15	LL LS2625	Strobo Gobo	33
LL LR81544R	Skylite Rapid Kit Midi	15	LL LS2701	Ezybox Pro Speedlight Bracket	25 - 29
LL LR822	Skylite Rapid Frame Large 2m x 2m (6'6" x 6'6")	15	LL LS2705	Ezybox Pro Elinchrom Quadra/Profoto Spigot	25 - 29
LL LR82201R	Skylite Rapid Cover Large 2m x 2m 0.75 Stop Diffuser	15	LL LS2710P	Ezybox Pro Square Small 45 x 45cm (18" X 18")	27
LL LR82202R	Skylite Rapid Cover Large 2m x 2m Black Velvet	15	LL LS2711P	Ezybox Pro Square Medium 60 x 60cm (24" X 24")	27
LL LR82206R	Skylite Rapid Cover Large 2m x 2m Sunfire / White	15	LL LS2712P	Ezybox Pro Square Large 90 x 90cm (35.5" x 35.5")	27
LL LR82207R	Skylite Rapid Cover Large 2m x 2m 1.25 Stop Diffuser	15	LL LS2720P	Ezybox Pro Octa Medium 99cm (39")	28
LL LR82221R	Skylite Rapid Cover Large 2m x 2m Black / White	15	LL LS2721P	Ezybox Pro Octa Large 1.2m (47")	28
LL LR82231R	Skylite Rapid Cover Large 2m x 2m Silver / White	15	LL LS2730P	Ezybox Pro Switch Large - Narrow 89 x 44cm (35" x 17") Wide 89 x 89cm (35" x 35")	29
LL LR82243RC	Skylite Rapid Kit Large	15	LL LS2731P	Ezybox Pro Switch Extra Large - Narrow 117 x 44cm (46" x 17") Wide 117 x 90cm (46" x 35.5")	29
LL LR833	Skylite Rapid Frame Extra Large 3m x 3m (10' x 10')	15	LL LS2810	EzyBounce Flashgun Bounce Card	18
LL LR83301R	Skylite Rapid Cover Extra Large 3m x 3m 0.75 Stop Diffuser	15	LL LS2950	Fabric Grids for Ezybox Pro Square - Small	27
LL LR83307R	Skylite Rapid Cover Extra Large 3m x 3m 1.25 Stop Diffuser	15	LL LS2951	Fabric Grids for Ezybox Pro Square - Medium	27
LL LR83344R	Skylite Rapid Kit Extra Large (Diffuser cover only included)	15	LL LS2952	Fabric Grids for Ezybox Pro Square Large / Switch Large (Wide)	27,29
LL LRCASE1025	Rigid Case 103cm x 19cm x 14cm	15	LL LS2953	Fabric Grids for Ezybox Pro Octa - Medium	28
LL LRCASE775	Rigid Case 78cm x 19cm x 14cm	15	LL LS2954	Fabric Grids for Ezybox Pro Octa - Large	28
LL LR8824	Studio Cubelite 70cm x 70cm x 155cm (28" x 28" x 61")	69	LL LS2955	Fabric Grids for Ezybox Pro Switch Large (Narrow)	29
LL LR8836	Studio Cubelite 100cm x 100cm x 185cm (39" x 39" x 73")	69	LL LS2956	Fabric Grids for Ezybox Pro Switch XLarge (Narrow)	29
LL LS1158	4 Section Standard Lighting Stand (Plastic Collars) Min 99cm (39") Max 310cm (122")	72	LL LS2957	Fabric Grids for Ezybox Pro Switch XLarge (Wide)	29
LL LS1159	4 Section Air Cush Stand, Metal Collars Min 99cm (39") Max 298cm (117")	72	LL LS2962	Fabric Grid For LL LS2462 Ezybox Hotshoe 54cm (21")	23
LL LS1160	4 Section Heavy Duty Air Cushioned Stand (Metal Collars) Min 104cm (41") Max 352cm (138.5")	72	LL LS2980	Fabric Grid For LL LS2480 Ezybox Hotshoe 76cm (30")	23
LL LS2211	Ezybox Micro 20cm x 14cm (8" x 5.5")	20	LL LS3030	Ezybox Pro Strip 150x30cm	26
LL LS2351N	Ezybox Pro Speedring Plate (Bowens)	25 - 29	LL LU2126	Brolly Grip Kit with 50cm (20") Translucent Umbrella	41
LL LS2352N	Ezybox Pro Speedring Plate (Elinchrom)	25 - 29	LL LU2127	Umbrella Trifold 98cm (39") Translucent	45
LL LS2353N	Ezybox Pro Speedring Plate (Balcar)	25 - 29	LL LU2473F	Umbrella Kit 84.5cm (33") + Stand, Hotshoe Tilthead and Padded Shoulder Bag	45
LL LS2354N	Ezybox Pro Speedring Plate (Profoto)	25 - 29	LL LU2474F	Umbrella Kit 101.5cm (40") + Stand, Hotshoe Tilthead and Padded Shoulder Bag	45
LL LS2362Q	Elinchrom Quadra Speedring	23	LL LU3207F	Umbrella Translucent 84.5cm (33") White	44
LL LS2400	Extending Handle 24cm - 48cm (9.5" - 19")	71	LL LU3212F	Umbrella Bounce PVC 84.5cm (33") White	44
LL LS2414	Ezybox Hotshoe Bracket (with standard flash mount)	23,31,34	LL LU3223F	Umbrella Dual 84.5cm (33") White Bounce / Translucent	43
LL LS2424	Off Camera Flash Cords Single eTTL Canon Pro 3m (10')	41	LL LU3237F	Umbrella All In One 84.5cm (33") Silver / White	43
LL LS2425	Off Camera Flash Cords Single iTTL Nikon Pro 3m (10')	41	LL LU4507F	Umbrella Translucent 101.5cm (40") White	44
LL LS2430	Ezybox Speed-Lite 2 22cm x 22cm (8.5" x 8.5")	21	LL LU4512F	Umbrella Bounce PVC 101.5cm (40") White	44
LL LS2430JM	Joe McNally Ezybox Speed Lite 2 Plus 22 x 22cm (8.5" x 8.5")	37	LL LU4523F	Umbrella Dual 101.5cm (40") White Bounce / Translucent	43
LL LS2436	Fabric Grid Ezybox Speed-Lite 2 22cm x 22cm	21,37"	LL LU4537F	Umbrella All In One 101.5cm (40") Silver / White	43
LL LS2438	Ezybox Hotshoe 38 x 38cm (15" x 15")	22	LL LU4538F	8:1 Umbrella 101.5cm (40")	42
LL LS2452	Non Rotating Extending Handle 70 - 176cm 27.5" - 69") with waitholder"	71	LL LU5038JM	Joe McNally 4:1 Umbrella 140cm (55")	38
LL LS2453	Non Rotating Extending Handle 74 - 232cm (29" - 91") with waitholder	71	LL LU7907F	Mega Umbrella 185cm (72") Translucent	44
LL LS2462	Ezybox Hotshoe 54cm x 54cm (21" x 21")	22	LL LU7908F	Mega Umbrella 160cm (63") Silver Parabolic	44
LL LS2469	Set Of 3 Creative Diffusers For 54cm (21") Ezybox Hotshoe	23	LL LU7915F	Mega Umbrella Kit Silver Parabolic Umbrella and 1 x Translucent Cover	44
LL LS2470	Ezybox Hotshoe Kit 3cm x 38cm (15" x 15") + Stand, Tilthead & Handle	23			
LL LS2471	Ezybox Hotshoe Kit 54cm x 54cm (21" x 21") + Stand, Tilthead & Handle	23			
LL LS2472	Ezybox Hotshoe Kit 76cm x 76cm (30" x 30") + Stand, Tilthead & Handle	23			
LL LS2480	Ezybox Hotshoe 76cm x 76cm (30" x 30")	22			
LL LS2530	Ezybox Pro Quad Bracket	35			
LL LS2535	Quad Bracket	35			

Distributor List

Country	Company	Telephone Number	Web Site
Argentina	Dexel SRL	+54 11 4687 3001	www.dexel.com
Argentina	Nicatel SRL	+54 11 4777 9797	www.teletecnica.com
Argentina	Santiago Distrifot SRL	+54 11 4308 3686	www.distrifot.com.ar
Australia	Kayell Australia Pty Ltd	+61 2 8423 7700	www.kayellaustralia.com.au
Austria	Photon GmbH	+43 7272 757970	www.foto-mueller.at
Bangladesh	Trade Corporation	+880 2 9555354	www.tradeco.com.bd
Belarus	Office Technologies JSC	+375 17 267 41 21	www.offtech.by
Belgium	Servix.BE	+32 3 887 77 20	www.servix.be
Bolivia	Dadco Technology	+591 78848871	www.dadcotechnology.com.bo
Bosnia Hercegovina	Refot BH d.o.o	+387 51 324 440	www.refot.com
Brazil	Lumatek Ltda.	+55 1150602900	www.tripes.com.br
Bulgaria	Dynaphos	+359 2 4901 555	www.dynaphos.com
Canada	Gentec International	+1 905 513 7733	www.manfrotto.ca/lastolite
Chile	Matrix LTDA	+56 2 237 29 911	www.matrixvideo.cl
China	Vitec Imaging Distribution Shanghai Ltd	+86 21 62360808	www.manfrotto.cn/lastolite
Columbia	Congo Films (COLOMBIA)	+57 1 630 4792	www.congofilms.tv
Costa Rica	Dima Industrial y Comercial S.A.	+506 2234 8500	www.dima.cr
Costa Rica	Imax de Costa Rica S.A.	+506 4051 0000	www.imax.co.cr
Croatia	Prizma d.o.o.	+385 1 3895 127	www.prizma-foto.hr
Cyprus	Mangoian Bros. Ltd	+357 22 672 928	www.mangoian.com
Czech Republic	E K G s.r.o.	+42 0495538132	www.ekgfoto.cz
Denmark	Aifo AB	+46 8 720 06 45	www.aifo.se
Estonia	Nordic Digital AS	+372 733 7700	www.nordic-digital.ee
Finland	Color-Kolmio Oy	+358 20 753 0359	www.colorkolmio.fi
France	Prophot	+33 1 81 72 01 03	www.prophot.com
Georgia	Zakhar LLC	+995 322 35 56 39	www.zakhar.ge
Germany	Vitec Imaging Distribution	+49 2203 202130	www.manfrotto.de/lastolite
Germany	Profot GmbH	+49 221 1709330	www.profot.de
Greece	H. Alexandrou & Co E.E.	+30 210 72 36 847	www.albapv.gr
Hong Kong	Vitec Imaging Distribution	+852 23276728	www.manfrotto.hk/lastolite
Hungary	Luminis Ltd.	+36 1 371 1983	www.manfrotto.hu
Iceland	Beco	+354 533 3411	www.beco.is
India	Srishti Digilife Private Limited	+91 44 24364778	www.srishtidigilife.co.in
Ireland	Hahnel Industries Ltd	+353 23 8841606	www.manfrotto.ie/lastolite
Israel	A.B.S. Altman Broadcast Services	+972 (0)3-7682000	www.absphoto.co.il
Italy	Vitec Imaging Distribution	+39 0424 555554	www.manfrotto.it/lastolite
Japan	Vitec Imaging Distribution	+81 3-5404-6871	www.manfrotto.jp/lastolite
Kazakhstan	Acis Distribution	+7 727 2642222	www.acis-d.com
Korea, South	Saeki P&C Co., Ltd.	+82 2 3668 3114	www.saeki.co.kr
Kuwait	Advanced Media Trading	+971 4 352 99 77	www.amt.tv
Kyrgyzstan	Acis Distribution	+7 727 2642222	www.acis-d.com
Latvia	Sia Mikrocentrs	+371 67450149	www.mikrocentrs.com
Lebanon	Gulbenk Corporation	+961 4 723 777	www.gulbenkcorporation.com
Lithuania	UAB Fototechnika	+370 658 00700	www.fototechnika.lt
Luxembourg	Lecuit Opto-Technical SA	389 23215985	www.lecuit.lu
Macedonia	Refot BH d.o.o	+389 23215985	www.refot.com
Malaysia	Shriro (Malaysia) Sdn Bhd	+60 3 7874 9842	www.shriro.com.my
Malta	The Foto Grafer Ltd	+356 21 66 01 66	www.thefotografer.com
Mexico	Turicia SA DE CV	+52 55 55 59 39 80	www.turicia.com
Moldova	Rolencom Srl	+373 22 63 66 56	www.rolencom.md
Morocco	Abchir	+212 522 86 44 51	www.abchir.ma
Nepal	New Snapper Photo Goods	+977 1223395	www.snapperphoto.com
Netherlands	Transcontinenta BV	+31 252 687 555	www.transcontinenta.nl
New Zealand	Lacklands LP	+64 9 630 0753	www.lacklands.co.nz
Norway	Bresson AS	+47 99 50 13 50	www.bresson.no
Pakistan	Super Enterprises	+92 42 37228254	www.camtronx.com.pk
Philippines	MQ Lighting Enterprises, Inc.	+63 28908858	www.mqlightings.com
Poland	Dicam	+48 22 631 48 78	www.dicam.pl
Romania	Simus Trading s.r.l.	+40 21 411 65 30	www.simus.ro
Russia	Flama LLC	+7 495 646 36 60	www.avras.ru
Russia	LLC Corporation DNK	+7 495 232-38-28	www.dnk.ru
Russia	LLC Light Style	+7 495 363 17 37	www.lsteam.ru
Saudi Arabia	Advanced Media Trading	+971 4 352 99 77	www.amt.tv
Serbia	Refot B	+381 11 3087004	www.refot.com
Singapore	Cathay Photo Store Pte Ltd	+65 6225 3788	www.cathayphoto.com.sg
Slovenia	Cumulus d.o.o.	+386 4 2016 534	www.cumulus.si
South Africa	Singer Photo	+27 11 791 2208	www.singerphoto.co.za
Spain	Cromalite SL	+34 93 436 05 61	www.cromalite.com
Sweden	Aifo AB	+46 8 720 06 45	www.aifo.se
Switzerland	Profot AG	+41 56 675 30 60	www.profot.ch
Taiwan	Cheng Seng Trading Co.,Ltd	+886 2 8511 1311	www.chengseng.com.tw
Thailand	Shriro Marketing (Thailand) Limited	+66 2 792 5000	www.shriromarketing.co.th
Turkey	Zoom lthalat	+90 212 269 7676	www.zoomlthalat.com
Turkmenistan	Acis Distribution	+7 727 2642222	www.acis-d.com
UAE	Advanced Media Trading	+971 4 352 99 77	www.amt.tv
UK	Vitec Imaging Distribution	+44 (0)1530 566090	www.manfrotto.co.uk/lastolite
Ukraine	M.I.K. LLC	+380 44 490 21 04	www.MIK.tv
USA	Vitec Imaging Distribution Inc	+1 201 818-9500	www.manfrotto.us/lastolite
Uzbekistan	Acis Distribution	+7 727 2642222	www.acis-d.com
Video Dealers			
Belgium	ES Broadcast Media	+32 16 40 40 20	www.broadcast-media.eu



Quality



Innovation



Portability

Resolution Road, Ashby De La Zouch, Leicestershire LE65 1DW UK